

*I-5 Columbia River Crossing Partnership:
Traffic and Tolling Analysis*

Traffic and Revenue Forecasts
for Tolling Options

Working Paper 10.2

Prepared by

Vollmer Associates LLP
Parisi and Associates

Date

January 27, 2005

TABLE OF CONTENTS

	Page
1. PURPOSE	1
2. FORECAST TRAFFIC VOLUMES.....	1
3. TOLLING METHODOLOGY	2
3.1 SELECT LINK ANALYSIS	3
3.2 TOLL I-5 ONLY SCENARIO	5
3.2.1 Diversion Criteria.....	5
3.2.2 Eliminated Trips	8
3.3 TOLL I-5 AND I-205 SCENARIO	9
3.3.1 Diversion Criteria.....	9
3.3.2 Elimination Criteria.....	9
3.4 TOLL RATES AND VEHICLE CLASSIFICATION ASSUMPTIONS	10
3.4.1 Toll Rate Assumptions	10
3.4.2 Vehicle Classification Assumptions	11
3.5 FORECAST YEAR TRAFFIC AND REVENUE	12
3.5.1 Toll I-5 Only Scenario	12
3.5.2 Toll I-5 and I-205 Scenario	13
4. MULTI-YEAR REVENUE FORECASTS FOR TOLL SCENARIOS	14
4.1 GROWTH RATES	14
4.2 TRAFFIC AND REVENUE STREAM.....	14
4.2.1 Toll I-5 Only Scenario	14
4.2.2 Toll I-5 and I-205 Scenario	16

List of Tables

Table 1. Columbia River Bridge Two-Way Traffic Volume Projections, Toll-Free Conditions.....	2
Table 2. 2020 Build Origin/Destination Sample Output - I-5 Bridge Toll-Free - Work Autos - PM Four-Hour Period.....	4
Table 3. 2020 Build Superzone O/D Sample Pairs - I-5 Bridge Toll-Free - Work Autos - PM Four-Hour Period.....	4
Table 4. 2020 Sample Bridge Use - 2020 Build PM Four-Hour Northbound Work Trips.....	6
Table 5. Reduction in Number of Trips Crossing River Due to Tolling I-5.....	9
Table 6. 2004 Equivalent Round-Trip Toll Charges.....	11
Table 7. Total Forecast Market Share.....	12
Table 8. Toll I-5 Only Scenario – Forecast Year Traffic and Revenue	12
Table 9. Toll I-5 and I-205 Scenario – Forecast Year Traffic and Revenue.....	13
Table 10. Toll I-5 Only Scenario – Annual Traffic Volumes and Toll Revenues	15
Table 11. Toll I-5 and I-205 Scenario – Annual Traffic Volumes and Toll Revenues.....	16

List of Figures

Figure 1. 2020 Build Select Link Origins and Destinations - I-5 Bridge Toll-Free - 24-Hour Weekday Total Trips - Northbound	5
Figure 2. Theoretical Toll Diversion Curves	7
Figure 3. Tolled Traffic Retention.....	8
Figure 4. Tolled Traffic Retention –2020 Build PM Four-Hour Peak Work Auto Trips – Southwest to Northeast Superzones	10
Figure 5. Toll I-5 Only Scenario – Annual Revenue	15
Figure 6. Toll I-5 and I-205 Scenario – Annual Revenue.....	17

Appendix A: Glossary

1. PURPOSE

The Oregon Department of Transportation (ODOT) and Washington State Department of Transportation (WSDOT) are preparing to undertake environmental studies of Columbia River Crossing Project alternatives. It is possible that tolling options will be included in these studies. The analysis documented in this Working Paper (WP) is preliminary in nature, and seeks only to provide tolling traffic and revenue information for project scoping. Three potential future options are addressed in this report: the No-Build, Tolling I-5 Only, and Tolling I-5 and I-205. A decision as to which, if any, of the tolling options to include in the environmental studies will be made through “project scoping.” A decision as to which, if any, tolling option will be recommended for implementation will occur at the conclusion of the environmental studies.

This WP discusses the methodology and presents the results of the traffic and revenue forecasting for a possible tolling scenario for the I-5 and possibly the I-205 Columbia River Crossings. The revenue forecasts were developed based on the toll rate structure assumptions summarized in Technical Memorandum 5.5 (TM 5.5).

A detailed tolling analysis was performed using Emme/2 regional travel demand model origin/destination information as the foundation of the study. AM Peak, PM Peak, and off-peak periods were treated separately, and each of the time periods was broken down into work trips, non-work trips, and truck trips to estimate which drivers would likely pay a toll to cross the river and which would either divert or eliminate the trip.

Analyses were performed using 2002 Existing, 2020 No-Build, and 2020 Build traffic volumes to generate toll-free and then tolled traffic estimates for two different tolling scenarios. The first tolling scenario, Toll I-5 Only Scenario, assumed that only I-5 is tolled in both northbound and southbound directions, providing a toll-free alternative route on I-205. The second tolling scenario, Toll I-5 and I-205 Scenario, assumed that both I-5 and I-205 were tolled, but only in one direction, either northbound or southbound.

This WP discusses how the 2002 Existing and 2020 No Build and Build river crossing volumes for I-5 and I-205 were used for this tolling study. The bridge origin and destination volumes and future projections for these years were used for the basis of the tolling analysis. Interim year traffic and revenue estimates were generated in order to create a traffic and revenue stream.

WP 11.1 provides a sensitivity analysis to the results reported herein. WP 11.1 shows how the results would vary based on changed assumptions regarding toll rates and traffic growth.

2. FORECAST TRAFFIC VOLUMES

The first step in estimating traffic and revenue forecasts for tolling one or both of the Columbia River bridges is to project future peak period and daily traffic volumes across the I-5 and I-205 bridges assuming that no tolls would be applied to either bridge. As discussed later in this WP, these toll-free forecasts will be used along with select link analyses for various vehicle-trip types to estimate traffic volume shifts and tolling revenue if one or both bridges were to operate as toll bridges.

Metro’s Emme/2 regional travel demand model was used during the Portland/Vancouver I-5 Transportation and Trade Partnership study to estimate year 2020 travel demands along I-5 and I-205 for several scenarios, including a No-Build scenario and a Build scenario. Under the No-Build scenario, no additional vehicle capacity would be added across the Columbia River. For the Build scenario, I-5’s six lanes crossing the Columbia River would be replaced with up to 10 lanes. Various capacity and operational improvements would also be made to I-5 within the Bridge Influence Area (BIA), the segment of I-5 extending from SR 500 in Vancouver to Columbia Boulevard in Portland.

The results from the Emme/2 model provided year 2020 3-hour AM and 4-hour PM peak hour volumes. These volumes were desegregated into peak hour volumes and adjusted to account for the differences between actual existing traffic count data and the model’s prediction of existing volumes. Adjustments were also made based on the corridor’s maximum carrying capacity. In some cases, the Emme/2 model predicted peak hour travel demands that could not be theoretically met based on existing or future capacity considerations. It is standard practice to make the adjustments since travel demand models are generally developed for regional forecasting and usually not calibrated for specific highway links.

Table 1 summarizes the adjusted year 2002 and 2020 traffic volume projections.

Table 1. Columbia River Bridge Two-Way Traffic Volume Projections, Toll-Free Conditions

Scenario	Daily - Weekday			AM Peak 3 Hours - Weekday			PM Peak 4 Hours - Weekday		
	I-5	I-205	Total	I-5	I-205	Total	I-5	I-205	Total
TRAFFIC VOLUMES									
Existing (2002)	124,000	136,000	260,000	22,500	28,700	51,200	35,800	43,100	78,900
2020 No-Build	140,400	155,200	295,600	24,800	32,700	57,500	39,400	49,200	88,600
2020 Build	178,600	136,100	314,700	33,600	28,300	61,900	53,300	42,250	95,550
PERCENTAGE CHANGE									
Existing to No-Build	13%	14%	14%	10%	14%	19%	10%	14%	12%
Existing to Build	44%	0%	21%	49%	-1%	21%	49%	-2%	21%
No-Build to Build	27%	-12%	6%	35%	-13%	1%	35%	-14%	8%

As shown in Table 1, total daily volumes across both bridges are anticipated to increase by 14 percent over an 18-year period under the No-Build condition. With additional capacity across the I-5 bridge, the forecast total daily volumes across both bridges would increase about 21 percent, a 6 percent increase for Build versus No-Build. Compared to No-Build conditions, under the Build scenario, I-5’s daily volumes would increase 27 percent, while I-205’s daily volumes would decrease by 12 percent to the level currently experienced. Thus, the added capacity in the I-5 corridor would result in some trips shifting from I-205 to I-5.

3. TOLLING METHODOLOGY

This section of the WP summarizes the steps that were taken to develop tolled traffic forecasts from the toll-free traffic volumes. Two different tolling scenarios were analyzed for this study: 1) Toll I-5 Only Scenario where the I-5 bridge is tolled in both directions, and 2) Toll I-5 and I-205 Scenario

where both the I-5 and the I-205 bridges are tolled in one direction. As discussed previously, the analysis is based on traffic volumes estimated for three scenarios for both the I-5 and I-205 crossings: 2002 Existing, 2020 No-Build, and 2020 Build toll-free volumes. The 2020 No-Build and Build volumes were analyzed to determine the impact that tolling would have in the forecast year, and then interim year traffic and revenue were estimated based on average annual growth rates. The following sections detail this analysis.

3.1 Select Link Analysis

A select link analysis was performed for both river crossings for 2002 Existing, 2020 No-Build, and 2020 Build conditions. Select link analyses identify where modeled trips using a selected roadway segment start and end. The select link analysis breaks down the trips on each bridge by the individual origin and destination (O/D) pairs using I-5 and I-205 under toll-free conditions.

The Emme/2 travel demand model also provides the number of trips by the trip type, including work, non-work and truck trips. The AM, PM, and off-peak periods were analyzed separately by the three trip purposes since the behavior for each trip type varies. Work trips are generally made at a certain time every day, whereas non-work trips may be more flexible and can often be combined with other trips. In general, truck trips behave differently than passenger car trips since truck drivers are paid by the mile and many drivers operate under tight timeframes and even tighter profit margins.

A sample analysis, used throughout this WP, describes how the tolling analysis is applied to the 2020 Build PM peak period trips. The example shows how the methodology works for one trip purpose in one direction during one PM period of the day. The same steps are taken for all of the other time periods and trip purposes and summed to determine the amount of daily traffic on each bridge and the amount of daily toll collections.

Table 2 shows a portion of the detailed O/D table. There are 22 origins and 22 destinations in the trip tables (484 O/D pairs) covering the Portland/Vancouver metropolitan region. These pairs were first consolidated into nine “superzones” (Far North, Downtown, etc.), with four zones covering the area north of the Columbia River and five covering the area to the south.

**Table 2. 2020 Build Origin/Destination Sample Output -
I-5 Bridge Toll-Free - Work Autos - PM Four-Hour Period**

Origin District	Destination District																						SUM
	1	2	3	4	5	6	7	8	9	10	11	12	13	14	15	16	17	18	19	20	21	22	
1	0	0	0	0	0	0	0	0	0	0	0	0	0	122	283	175	94	612	124	85	50	0	1,544
2	0	0	0	0	0	0	0	0	0	0	0	0	0	43	97	37	25	267	90	20	22	0	602
3	0	0	0	0	0	0	0	0	0	0	0	0	0	89	188	174	173	376	145	73	19	0	1,236
4	0	0	0	0	2	0	0	0	28	163	0	0	75	209	422	613	393	804	296	155	39	6	3,204
5	0	0	0	9	0	0	0	0	0	0	0	0	0	111	206	208	130	383	117	58	27	0	1,246
6	0	0	0	0	0	0	0	0	0	0	0	0	0	179	359	495	362	706	265	135	40	0	2,541
7	0	0	0	1	0	0	0	0	0	0	0	0	0	43	65	15	4	122	27	4	10	0	290
8	0	0	0	0	0	0	0	0	0	0	0	0	0	54	106	156	105	200	76	39	8	0	744
9	0	0	0	6	0	0	0	0	0	0	0	0	0	45	69	11	4	137	34	5	12	0	323
10	0	0	0	52	0	0	0	0	0	0	0	0	0	0	0	0	0	0	0	0	0	0	52
11	0	0	0	0	0	0	0	0	0	0	0	0	0	25	47	35	25	89	33	16	4	0	275
12	0	0	0	0	0	0	0	0	0	0	0	0	0	109	215	189	173	421	154	79	17	0	1,358
13	0	0	0	13	0	0	0	0	0	0	0	0	0	17	28	10	4	52	14	5	4	0	148
14	18	8	20	93	29	106	77	22	34	0	25	63	20	0	0	0	0	0	0	0	0	130	646
15	38	15	32	109	38	119	61	25	31	0	24	70	16	0	0	0	0	0	0	0	0	106	683
16	21	5	32	118	34	119	9	29	4	0	13	56	3	0	0	0	0	0	0	0	0	95	539
17	5	3	20	56	18	53	0	15	1	0	3	27	1	0	0	0	0	0	0	0	0	11	211
18	80	36	53	136	60	136	50	33	35	0	22	81	16	0	0	0	0	0	0	0	0	76	815
19	16	13	19	42	18	39	7	11	7	0	6	23	3	0	0	0	0	0	0	0	0	14	216
20	13	5	10	25	8	25	2	6	2	0	4	15	1	0	0	0	0	0	0	0	0	19	137
21	19	8	7	15	12	16	4	3	4	0	2	7	1	0	0	0	0	0	0	0	0	98	98
22	0	0	0	2	0	0	0	0	0	0	0	0	0	36	29	29	4	21	4	5	0	0	130
SUM	211	91	194	675	218	613	211	144	146	163	98	341	136	1,081	2,113	2,147	1,498	4,191	1,378	678	252	457	17,036

Source: I-5 Partnership Districts summarized 9/27/04 from I-5 Partnership Data for Columbia River Tolling Project - 2020 LRT/3-Lane PM 4-Hour I-5 Bridge Select Link OD Volumes Work Autos

Table 3 shows a summary of superzone origins and destinations for the 2020 Build PM peak period work auto trips on the I-5 bridge, while Figure 1 graphically represents the O/D superzone pairs for the 2020 Build 24-hour weekday northbound work auto trips on the I-5 bridge. Both examples are for the toll-free condition.

**Table 3. 2020 Build Superzone O/D Sample Pairs -
I-5 Bridge Toll-Free - Work Autos - PM Four-Hour Period**

Origin Superzone	Destination Superzone									SUM
	Far North	Northwest	North Central	Northeast	Downtown	Southwest	South Central	Southeast	Far South	
Far North	0	0	0	0	85	169	54	4	14	326
Northwest	0	0	0	0	222	740	294	37	213	1,506
North Central	0	0	0	0	88	358	134	17	109	706
Northeast	0	0	0	0	118	582	81	5	129	915
Downtown	465	1,558	586	884	0	0	0	0	0	3,493
Southwest	962	2,887	1,186	3,066	0	0	31	246	6	8,384
South Central	234	868	351	453	0	17	0	0	0	1,923
Southeast	19	71	29	20	0	67	0	0	0	205
Far South	4	59	30	39	0	2	0	0	0	134
SUM	1,684	5,443	2,183	4,462	512	1,936	594	309	472	17,594

**Figure 1. 2020 Build Select Link Origins and Destinations -
I-5 Bridge Toll-Free - 24-Hour Weekday Total Trips - Northbound**

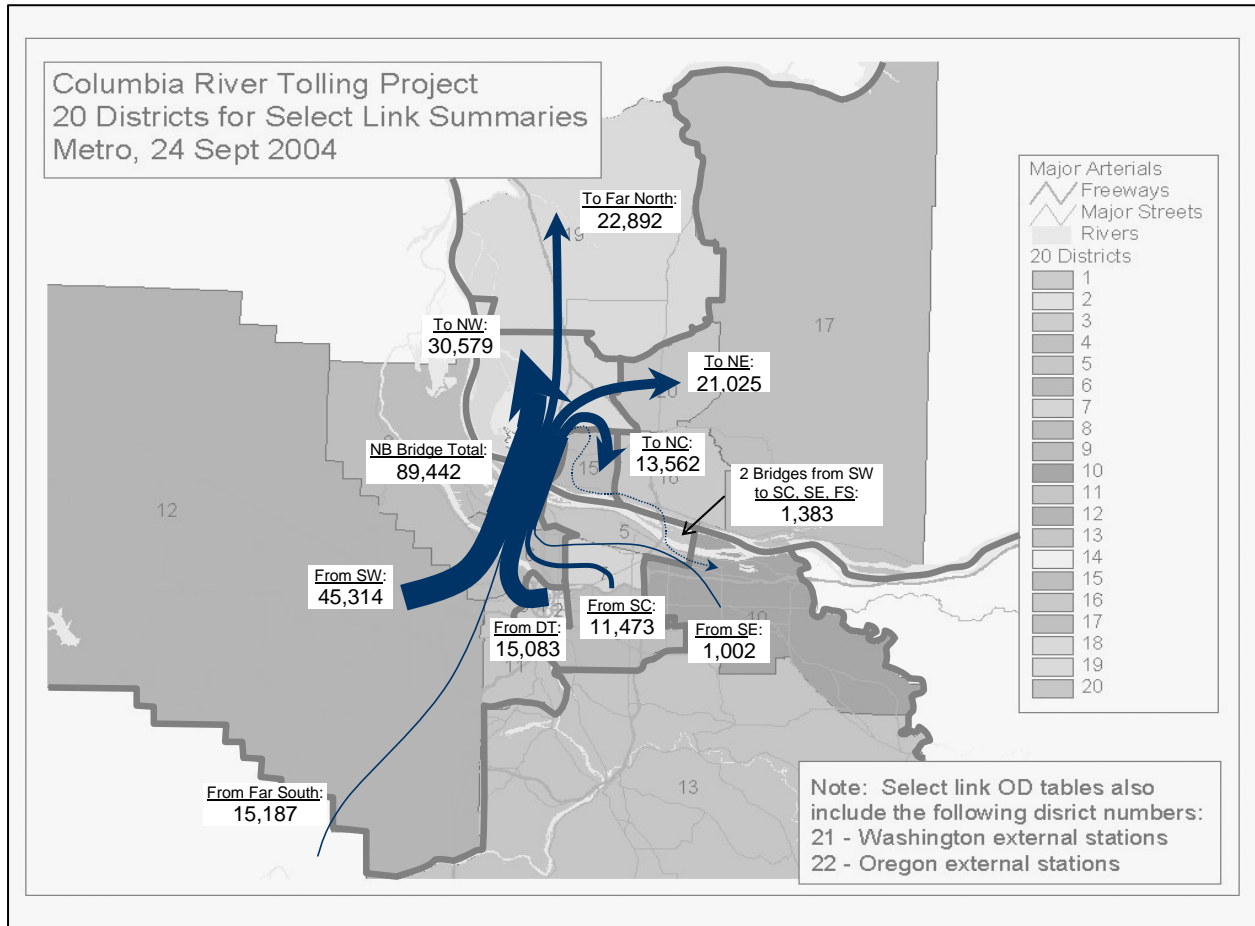

3.2 Toll I-5 Only Scenario

3.2.1 Diversion Criteria

It is common in tolling studies to use “time saved” criteria to estimate which users will be likely to pay a toll to use a facility, and which will change travel patterns. However, a slightly different methodology was used to develop diversion criteria for the I-5 bridge, as discussed below.

For the Toll I-5 Only Scenario in which the I-205 bridge would remain free, a surrogate was used for time saved by analyzing the existing and forecasted use of each facility by trip O/D pair. By summarizing total river crossing traffic by O/D and trip type, and then determining the toll-free forecast share of each facility, the model was able to estimate which route was the most efficient for any given O/D pair. For some of the O/D pairs, a high percentage (e.g. 90 to 100 percent) of all trips crossing the river were directly assigned to either one bridge or the other. In the Toll I-5 Only Scenario, the time required for many of these trips to divert to the toll-free I-205 bridge would be significant, and the driver would likely pay a toll on the more convenient I-5 bridge. However, for the O/D pairs in which a moderate to low percentage of the trips are forecasted to use the I-5 bridge, the diversion rates for trips switching to I-205 in order to avoid the toll on I-5 would be higher.

Table 4 provides samples of some of the O/D pairs and their toll-free bridge use shares for 2020 PM peak period work auto trips. In this example, 89 percent (3,066) of the northbound work trips from Southwest (SW) to the Northeast (NE) would use the I-5 crossing. If the I-5 bridge were tolled, a large share of this traffic would remain on I-5 and pay the toll since the I-5 bridge is obviously the most efficient route for travel between these two locations. Similarly, 46 percent (884) of the trips from Downtown (DT) to the NE use the I-5 crossing. If I-5 were tolled, it is logical to assume that a large number of these 884 trips would change their travel pattern to use I-205.

Table 4. 2020 Sample Bridge Use - 2020 Build PM Four-Hour Northbound Work Trips

Origin	Destination	Toll-Free Trips			% I-5 Traffic
		I-5	I-205	Total	
Downtown	Far North	465	17	481	97%
	Northwest	1,558	0	1,558	100%
	North Central	586	0	586	100%
	Northeast	884	1,032	1,915	46%
Southwest	Far North	962	0	962	100%
	Northwest	2,887	0	2,887	100%
	North Central	1,186	0	1,186	100%
	Northeast	3,066	371	3,438	89%
South Central	Far North	234	551	786	30%
	Northwest	868	621	1,490	58%
	North Central	351	336	687	51%
	Northeast	453	4,389	4,842	9%
Southeast	Far North	19	415	433	4%
	Northwest	71	519	590	12%
	North Central	29	281	300	10%
	Northeast	20	2,688	2,708	1%
Far South	Far North	4	3	7	55%
	Northwest	59	23	82	72%
	North Central	30	14	44	67%
	Northeast	39	70	109	36%

In summary, the percentage of total toll-free cross-river traffic using the I-5 bridge is an indicator of the potential travel times savings for each O/D pair using that bridge. Those O/D pairs that have a high percentage of total cross-river traffic using the I-5 bridge are assumed to have a relatively high travel time savings as compared to using the I-205 bridge to cross the river. Therefore, these pairs have a low potential diversion rate if tolls were implemented. Those O/D pairs that have a lower percentage of total cross-river traffic using the I-5 bridge are assumed to have a lower times savings as compared to using the I-205 bridge to cross the river. Therefore, these pairs have a higher potential diversion rate if toll were implemented.

Figure 2 shows a hypothetical curve used in tolling methodologies to determine the percentage of traffic using a tolled facility based on varying amounts of time saved. The left side of the x-axis represents a high number of minutes saved by taking the toll route, and the right side of the x-axis represents small time savings. With large time savings, the percentage of traffic using the toll lanes is high, and it decreases as the benefit provided by the toll lanes decreases. This represents the basic theory behind toll diversion and retention.

Figure 2. Theoretical Toll Diversion Curves

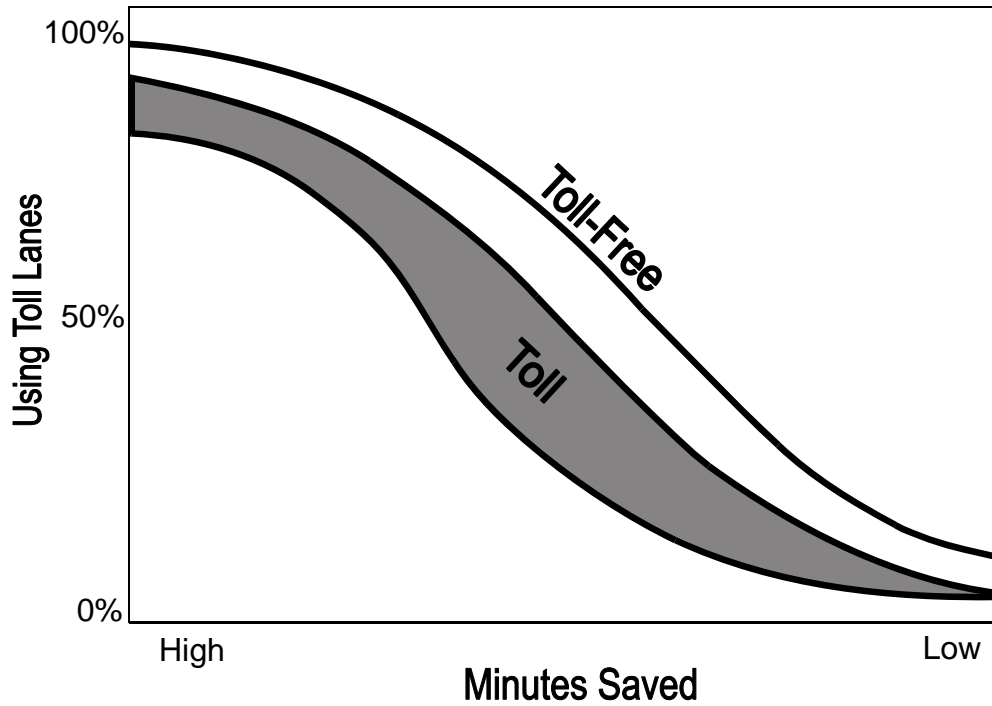

Using the percentage of forecast toll-free cross-river traffic using the I-5 bridge as an indicator of travel times savings, a retention curve was developed as shown in Figure 3 for a \$2.00 (2004 equivalent to \$3.25 in 2020) toll rate. This retention curve was developed using a compilation of historic traffic data collected on toll roads, and is not based on the data from one particular facility. The data presented in this figure shows that when the I-5 bridge has a low share of the river crossing traffic, the retention on tolled I-5 is low. When the I-5 bridge has a higher share of the river crossing traffic (i.e., it is most efficient to use I-5 rather than I-205), the retention rate on tolled I-5 is higher.

Figure 3. Tolled Traffic Retention

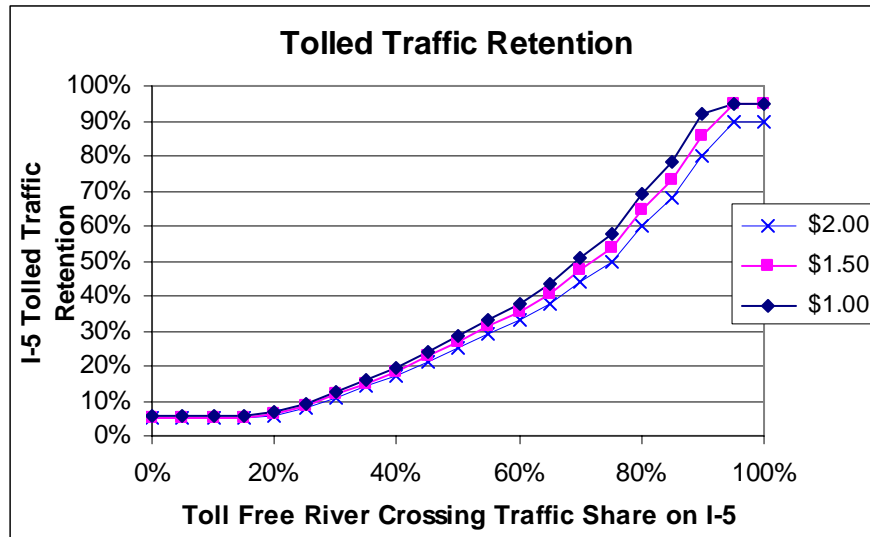

The curve for the \$2.00 toll is the base curve in this analysis. Other toll rates were developed using a constant elasticity to generate a sample of toll rate curves. As shown in Figure 3, the retention for a \$1.00 toll is higher than for a \$2.00 toll at the same point on the x-axis. These lower toll rate curves were used for the discounted toll rate analyses. While the retention curves would be different for different trip purposes, this analysis utilizes, for each toll rate, a prototypical curve for all trip purposes. The limitations of this methodology are not significant, and would not lead to a materially different conclusion than shown later in this report.

From the previous example (see Table 3), 3,066 of the 3,438 SW to NE river crossings (89 percent) use the I-5 bridge if it is toll-free. Under a tolled scenario, a 68 percent retention rate would be the base retention rate to be applied for this cash toll with a diversion rate of 32 percent to I-205. However, during peak periods, the diversion rate is assumed to be 50 percent of the base rate to account for the time sensitivity of commuting and peak period trips. Therefore, the peak period diversion rate would be 16 percent and the 68 percent retention would become 84 percent retention. The retention curves do not reach 0 percent or 100 percent retention, since there will always be trips that are made that are not completely logical. Some trips will always pay a toll because some drivers find toll roads easier to follow. Other drivers simply follow directions that lead them to a toll road, although it might not be the shortest route. And, some trips will never pay a toll and always avoid a toll road.

3.2.2 Eliminated Trips

The above curve shows the relationship of trips that are *retained* on the I-5 bridge under a tolled condition. Of the trips that are diverted, some switch to the I-205 bridge for a toll-free ride, while other trips are either eliminated or consolidated with another trip, thereby reducing the total number of trips crossing the Columbia River.

As mentioned previously, each of the trip purposes are analyzed separately, and the share of diverted trips that are eliminated vary for work, non-work and truck trips. Table 5 shows the assumptions that

were made in modeling the difference in eliminated trips for the different trip purposes. These values are based on information gathered from toll roads in other states that raised existing toll rates, and have been applied to this tolling scenario. There is no available data that can be used to extract trip purpose diversion behavior information in which an existing toll free facility was been tolled.

Table 5. Reduction in Number of Trips Crossing River Due to Tolling I-5

Trip Purpose	Number of Trips No Longer Crossing River Due to Tolls on I-5
Work	15% of the work trips projected to be diverted from I-5 would no longer cross river
Non-Work	30% of the non-work trips projected to be diverted from I-5 would no longer cross river
Truck	15% of the truck trips projected to be diverted from I-5 would no longer cross river

Figure 4 summarizes the various steps taken during the I-5 only toll scenario, focusing on the 2020 Build PM Peak work trip example.

Computations like that shown in Figure 4 were done for each zonal (origin-destination) pair, for each trip purpose, and for each time period. The totals were then added to project the daily traffic volumes on each bridge.

3.3 Toll I-5 and I-205 Scenario

3.3.1 Diversion Criteria

The analysis performed for the Toll I-5 and I-205 Scenario is significantly different from the previous discussion of the Toll I-5 Only Scenario since no toll-free alternative would exist for a round trip made across the river. In this scenario, one-way tolls would be collected in either the southbound or the northbound direction on both I-5 and I-205, and trips could not easily divert to another route to avoid the toll. Therefore, the previously shown retention curves are not applicable to this scenario. The methodology assumes that there will be no diversion of trips from one bridge to the other due to the tolling of the bridges.

3.3.2 Elimination Criteria

While it is assumed that trips will not be diverted from one bridge to another, there will be a reduction in trips crossing the river due to the tolls. Since a toll-free route is not an option in this scenario, a greater number of trips would be eliminated due to trip consolidation and/or reduction than would occur when the tolls are applied. Based on similar studies performed elsewhere, it was assumed that 5 percent of *all* trips will be eliminated when both the I-5 and I-205 bridges are tolled in one direction. This is significantly different than the previous scenario in which only the I-5 bridge was tolled in two directions, since between 15 and 30 percent of the otherwise diverted trips were assumed to be eliminated.

Figure 4. Tolloed Traffic Retention –2020 Build PM Four-Hour Peak Work Auto Trips – Southwest to Northeast Superzones

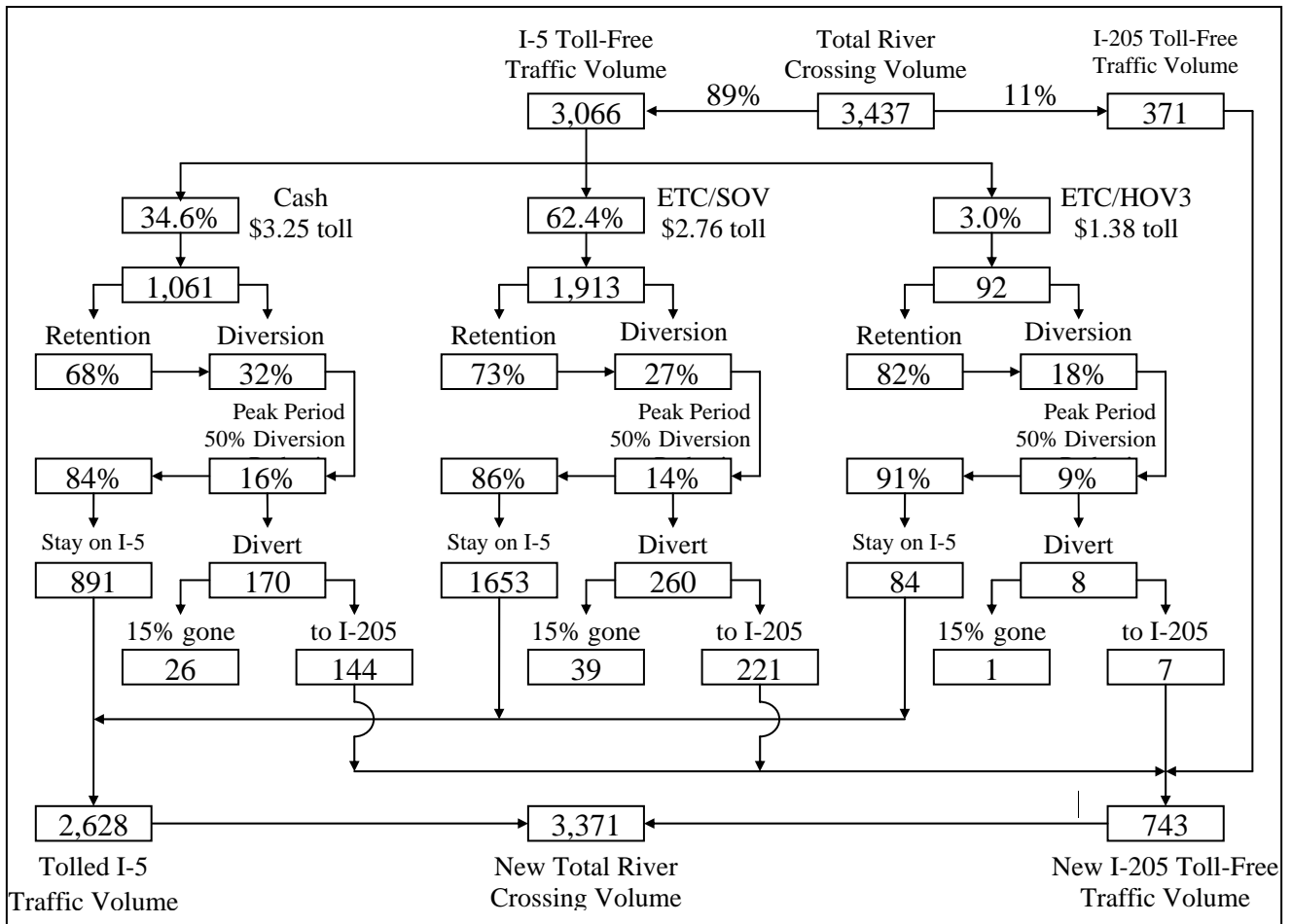

3.4 Toll Rates and Vehicle Classification Assumptions

The tolling analyses have been segmented by vehicle classification and payment methodology. While there is no available frequency of use information, the characteristics of traffic in the area are high in commuter trips during peak periods, which tend to be frequent trips made at the same times every day. In other tolled areas, these trips are more likely to be able to carpool than the infrequent, more irregular trips in the corridor. In addition, frequent users of the facilities can save money by using the Electronic Toll Collection (ETC) discounted rates, which are assumed in this analysis.

3.4.1 Toll Rate Assumptions

As discussed in TM 5.5 and WP 5.1, ETC discounts and High Occupancy Vehicle (HOV) discounts have been assumed to be available to ETC customers, and truck tolls have been assumed to be charged

at the N-1¹ rate times the passenger car tolls. This tolling analysis assumed that the toll charged would be \$2.00 in 2004 dollars, and the toll rate would increase in 25-cent increments mimicking a 3 percent inflation rate, and there would be no “real” toll increases above the inflation rate for the duration of this estimate. This assumption can be modified during sensitivity and other financing model runs. It has also been assumed that the new I-5 bridge would be open and tolls would be charged beginning in 2013, so although this report shows 2004 toll rates, collection would actually begin in 2013.

The Toll I-5 Only Scenario, in which I-5 is tolled in both directions, assumes a \$2.00 cash toll (in 2004 dollars) is collected from passenger cars in **both** the northbound and southbound directions. A truck would pay an \$8.00 toll (assuming an average truck has five axles) in **both** the northbound and southbound directions. Therefore, the round trip cash toll for a passenger car using I-5 would be \$4.00 (in 2004 dollars), while a round trip on I-205 would be free.

The Toll I-5 and I-205 toll Scenario assumes that a \$2.00 toll is collected from passenger cars on both I-5 and I-205 in either the southbound or northbound direction. A round trip on I-5 would be \$2.00 and a round trip on I-205 would also be \$2.00. Table 6 details the 2004 equivalent toll collected for each vehicle payment type.

Table 6. 2004 Equivalent Round-Trip Toll Charges

Tolling Scenario	Vehicle Type	Cash	ETC	ETC/HOV
Toll I-5 Only Scenario	Passenger Car	\$4.00	\$3.40	\$1.70
	Truck (avg. toll)	\$16.00	\$13.60	N/A
Toll I-5 and I-205 Scenario	Passenger Car	\$2.00	\$1.70	\$0.85
	Truck (avg. toll)	\$8.00	\$6.80	N/A

3.4.2 Vehicle Classification Assumptions

The makeup of traffic during different times of the day can vary greatly. During the AM peak period, work trips constitute a large share of the traffic on the river crossings. During the PM peak period, the same work trips are being made, but there are also shopping and other trips occurring at the same time. In addition, the peak commuting periods are more likely to have carpool opportunities than other times of the day. Commercial vehicle trips occur throughout the day, with many trucks trying to avoid congested peak periods of traffic.

Table 7 shows the shift in ETC market penetration and change in HOV activity between the opening year and the 2020 build year conditions. The overall ETC market share is estimated at approximately 30 percent in the opening year, and is expected to grow to almost 66 percent in the 2020 Build condition.

¹ The N-1 toll rate for trucks is calculated as the passenger car toll rate times one less than the total number of truck axles. So, for example and under the assumptions stated herein, the toll for a six-axle truck in the “Toll I-5 Only” Scenario would be \$4.00 (the passenger car toll rate) X 5 (six axles (N=6) minus one) = \$20.00.

Table 7. Total Forecast Market Share

Travel Period	Trip Type	Opening Year			2020 Build		
		Cash	ETC	ETC/HOV	Cash	ETC	ETC/HOV
PM Peak	Work	70.0%	28.8%	1.2%	34.6%	62.4%	3.0%
	Non-Work	70.0%	28.8%	1.2%	34.6%	62.4%	3.0%
	Truck	70%	30%	0%	40%	60%	0%
AM Peak	Work	70.0%	28.8%	1.2%	34.6%	62.4%	3.0%
	Non-Work	70.0%	28.8%	1.2%	34.6%	62.4%	3.0%
	Truck	70%	30%	0%	40%	60%	0%
Off Peak	Work	75.0%	24.5%	0.5%	39.8%	58.8%	1.4%
	Non-Work	75.0%	24.5%	0.5%	39.8%	58.8%	1.4%
	Truck	75%	25%	0%	40%	60%	0%

3.5 Forecast Year Traffic and Revenue

Applying the methodologies and assumptions outlined above, the forecast toll-free traffic was used to determine the tolled traffic and revenue for the years 2002 No-Build and 2020 in the Build and No-Build conditions. The two tolling scenarios (Toll I-5 Only Scenario and the Toll I-5 and I-205 Scenario) were analyzed. There are no scenarios in which either bridge is tolled in 2002, or in which either bridge is tolled under the No-Build. These calculations are used to help develop the revenue stream for the Build condition.

3.5.1 Toll I-5 Only Scenario

To develop initial revenue forecasts, both Build and No-Build traffic volumes were assumed tolled in both directions on I-5 for this tolling scenario. Table 8 details the resulting tolled traffic and revenue numbers, assuming that a hypothetical \$2.00 cash toll was applied to the No-Build 2002 traffic volumes and an equivalent \$3.25 cash toll was applied to the 2020 conditions. The “tolled” rows show the tolled traffic on I-5 and the resulting toll-free traffic on I-205.

Table 8. Toll I-5 Only Scenario – Forecast Year Traffic and Revenue

Scenario		I-5 (AWD) tolled	I-205 (AWD) (toll-free)	Total (AWD)	Revenue (Annual)
2002	Toll-Free	124,000	136,000	260,000	
	Proforma Tolled	90,400	165,600	256,000	\$64.6 m
2020 No-Build	Toll-Free	140,400	155,200	295,600	
	Tolled	99,600	191,700	291,300	\$111.1 m
2020 Build	Toll-Free	178,600	136,100	314,700	
	Tolled	131,400	167,200	298,600	\$150.7 m

AWD = Average Weekday Daily Traffic

In 2002, the I-5 bridge traffic would be reduced by 33,600 vehicles per day (vpd), about 27 percent, when the tolls were theoretically applied. I-205 would gain 29,600 vpd, which is 88 percent of the I-5 diverted traffic. The remaining 4,000 vehicles would either be combined with another trip or

eliminated. (This step is performed for the tolling analysis to provide additional points in the projection, and is not to be used for any other purpose in the analysis.)

Using 2020 No-Build projections, applying a theoretical toll to I-5 would reduce the traffic by 40,800 vpd (29 percent reduction). Again, a toll will **not** be applied in the no-build condition. Approximately 89 percent of these diverted trips would be reassigned to the I-205 crossing, which would increase by 36,500 vpd. The total river crossing traffic in the 2020 No-Build would be reduced by 4,300 vpd due to eliminated trips.

In the 2020 Build condition, additional capacity on the I-5 bridge would increase the overall daily river crossing by about 6.5 percent over the toll-free No-Build (peak period percentage increases are forecast to be even greater). If I-5 were tolled, traffic volumes would decrease by 47,200 vpd (26 percent reduction). Approximately 66 percent of those diverted trips (31,100 vpd) would relocate onto the I-205 bridge, while the overall river crossing volumes would be reduced by 16,100 vpd when tolls were applied to I-5.

The forecast year traffic and revenue will be broken down further by time of day and direction in WP 11.1.

3.5.2 Toll I-5 and I-205 Scenario

Build and No-Build condition traffic volumes are assumed tolled in one direction only on I-5 and I-205 for this scenario to help develop the revenue stream for the Build condition.

Table 9 details the resulting tolled traffic and revenue numbers, assuming that a hypothetical toll was applied to the No-Build 2002 traffic volumes and an equivalent \$3.25 cash toll was applied to the 2020 conditions.

Table 9. Toll I-5 and I-205 Scenario – Forecast Year Traffic and Revenue

Scenario		I-5 (AWD) (toll one direction)	I-205 (AWD) (toll one direction)	Total (AWD)	Revenue (Annual)
2002	Toll-Free	124,000	136,000	260,000	
	Proforma Tolled	117,300	128,600	245,900	\$88.2 m
2020 No-Build	Toll-Free	140,400	155,200	295,600	
	Tolled	133,000	147,000	280,000	\$162.3 m
2020 Build	Toll-Free	178,600	136,100	314,700	
	Tolled	165,800	126,400	292,200	\$168.4 m

Traffic would change on I-5 and I-205 about 6 to 8 percent between the toll-free and tolled conditions. This reduction in river crossing traffic would be greater than in the Toll I-5 Only Scenario because there is no toll-free alternate route for the trips. A 5 percent reduction in trips was applied to trips with O/Ds on opposite sides of the river. The overall traffic reduction is higher than 5 percent because the EMME/2 model had assigned some trips with O/D pairs on the same side of the river to cross both bridges. It was assumed that these trips were rerouted under tolled conditions.

The forecast year traffic and revenue broken down into period of the day and vehicle classification is discussed in WP 11.1.

4. MULTI-YEAR REVENUE FORECASTS FOR TOLL SCENARIOS

Up to this point in the traffic and revenue study: (a) traffic projections were based on data provided by Metro as toll-free output for the year 2020, and (b) Metro's year 2020 toll-free traffic volumes were adjusted to account for tolling in both the Toll I-5 Only and Tolling I-5 and I-205 Scenarios, for both the Build and No-Build alternatives in the year 2020. The next step in this analysis is to determine the interim year traffic and revenue numbers. Toll collection is assumed to begin 2013 and is projected out to the year 2025. A companion working paper, WP 11.1, extends these projections through year 2043 and also evaluates elasticity of different toll rates and estimates gross and net revenues.

4.1 Growth Rates

The average annual growth rate calculated between 2002 as the starting point and 2020 No-Build toll-free as the ending point, is 0.69 percent for I-5 and 0.74 percent for I-205. This rate was applied to the interim year No-Build volumes to generate a traffic stream from 2002 through 2025. For the Build condition, it is assumed that these same No-Build growth rates are applied to the traffic streams between 2002 and 2012, just prior to the opening of the new I-5 river crossing (the Build and No-Build volumes between 2002 and 2012 are identical). For simplicity, these same growth rates are applied to the higher 2020 Build volumes to determine the volumes in 2013 through 2025 in both the tolled and toll-free analyses. Sensitivities on the traffic volume growth rates will be analyzed in WP 11.1.

4.2 Traffic and Revenue Stream

The resulting traffic volumes for the two tolling scenarios are shown in Table 10 and Table 11 and illustrated in Figure 5 and Figure 6. The new crossing is assumed open and tolled in 2013. It is also assumed that there is latent demand that would be met with the opening of the new crossing and its higher capacity; therefore the river crossing volumes would increase between 2012 and 2013. In reality, there may be a ramp-up period of a year or two, but this report assumes that the growth due to the increased capacity of the new crossing would occur in year one. The No-Build river crossing volume in 2013 is estimated at 280,900 vpd, and the Build volume is estimated at 299,500 vpd under toll-free conditions, which is an increase of approximately 6.6 percent over the No-Build.

4.2.1 Toll I-5 Only Scenario

The Toll I-5 Only Scenario assumes that I-5 is tolled in both the northbound and southbound directions (\$2 each way in 2004 dollars, or \$4.00 round-trip), and I-205 is toll-free. The 2013 Build total river crossing in this tolled scenario is estimated at 291,500 vpd, an increase of 8,000 trips compared to the toll-free condition. Some trips that would normally use I-5 would switch to I-205 to avoid the toll, and other trips would be consolidated or eliminated. Table 10 and Figure 5 show the interim year traffic and revenue streams for the build condition.

Toll rates are assumed to increase in 25-cent increments under a 3 percent inflation rate. Using these assumptions, toll rates increase in 2017, 2020, 2022, and 2025. Each year in which toll rates increase, a one-time traffic reduction is applied to the tolled traffic to account for drivers who will initially forego their trip when tolls are raised. This behavior is eliminated after the first year of the toll increase.

Table 10. Toll I-5 Only Scenario – Annual Traffic Volumes and Toll Revenues

Year	I-5 Traffic (AWD) (tolled)	I-205 Traffic (AWD) (toll-free)	Total Annual Toll Revenue ^{1,2}
2013	127,400	157,800	\$127,406,700
2014	128,100	158,700	\$127,619,600
2015	129,000	159,900	\$127,848,400
2016	129,800	161,100	\$128,093,400
2017	128,800	163,400	\$138,100,100
2018	131,600	163,700	\$140,327,400
2019	132,400	165,000	\$140,650,000
2020	131,400	167,200	\$150,654,200
2021	134,200	167,500	\$153,132,200
2022	133,100	169,800	\$163,105,500
2023	136,000	170,100	\$165,824,200
2024	136,900	171,400	\$166,316,300
2025	135,800	173,800	\$176,330,900

¹Note that revenue projects in this Table 10 assume a \$4.00 round trip toll rate (year 2004 dollars) for passenger cars (and the associated “N-1” toll rate for trucks), whereas the revenue projections in Table 11 assume a \$2.00 toll rate for passenger cars.

²Total annual revenues are gross collections; they are **not** net of operations costs. WP 11.1 addresses operation costs and provides net revenue projections.

Figure 5. Toll I-5 Only Scenario – Annual Revenue

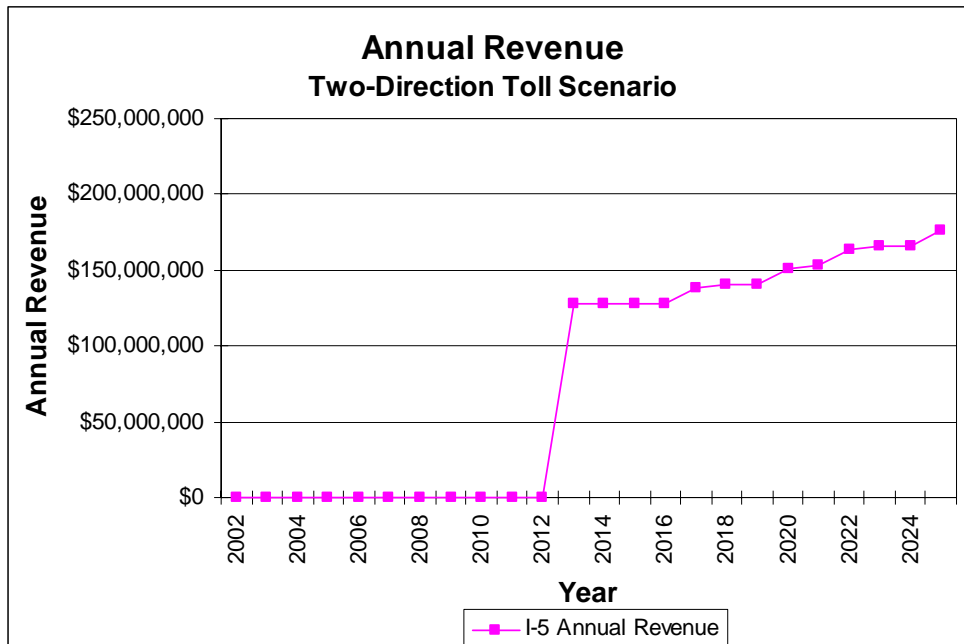

4.2.2 Toll I-5 and I-205 Scenario

Under the Toll I-5 and I-205 Scenario, the 2013 No-Build and Build toll-free numbers are the same as in the above situation. However, a greater number of trips would be eliminated or consolidated in this tolling scenario since both crossings would be tolled and there would be no free alternative. The traffic volume growth due to the latent demand served by the increased bridge capacity would be offset due to the tolling impact. The total 2013 tolled Build river crossing volume is estimated at 292,200 vpd, compared to the toll-free volumes of 314,700 vpd.

Table 11 and Figure 10 detail the annual traffic and revenue values for the Toll I-5 and I-205 Scenario. The toll increase year traffic adjustment is also applied to this scenario.

Table 11. Toll I-5 and I-205 Scenario – Annual Traffic Volumes and Toll Revenues

Year	I-5 Traffic (AWD) (tolled 1-way)	I-205 Traffic (AWD) (tolled 1-way)	Total Annual Toll Revenue ^{1,2}
2013	159,800	120,600	\$141,750,800
2014	160,800	121,200	\$141,853,000
2015	161,800	122,200	\$142,065,600
2016	162,900	123,100	\$142,290,600
2017	162,500	123,600	\$154,609,700
2018	165,200	125,100	\$155,951,500
2019	166,300	126,000	\$156,240,700
2020	165,800	126,400	\$168,435,400
2021	168,700	127,900	\$169,927,900
2022	168,200	128,300	\$182,137,600
2023	171,000	129,900	\$183,779,700
2024	172,200	130,800	\$184,196,900
2025	171,800	131,200	\$196,488,600

¹Note that revenue projects in this Table 11 assume a \$2.00 round trip toll rate (year 2004 dollars) for passenger cars (and the associated “N-1” toll rate for trucks), whereas the revenue projections in Table 10 assume a \$4.00 toll rate for passenger cars.

²Total annual revenues are gross collections; they are **not** net of operations costs. WP 11.1 addresses operation costs and provides net revenue projections

Figure 6. Toll I-5 and I-205 Scenario – Annual Revenue

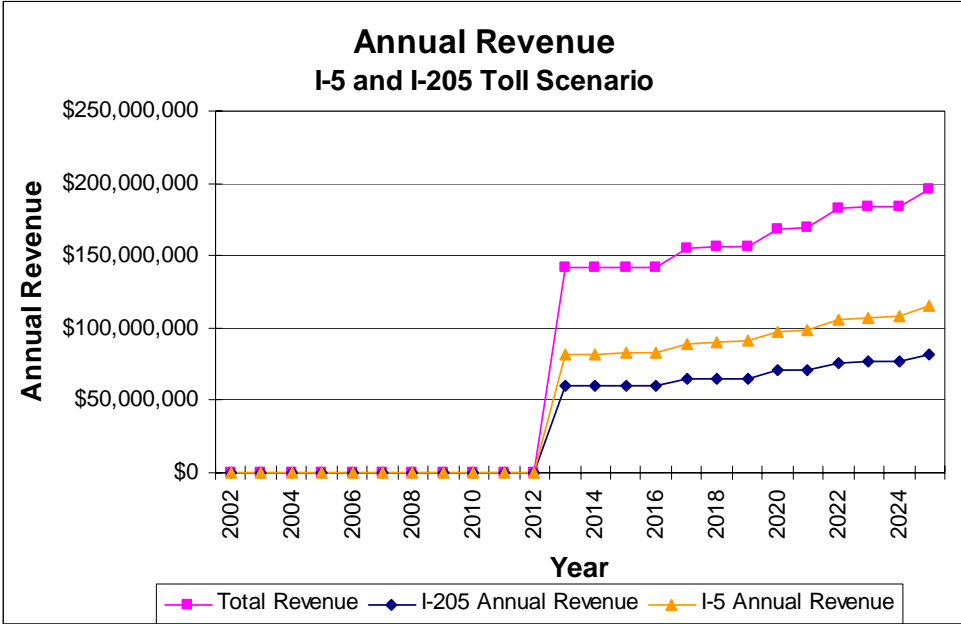

APPENDIX A

Glossary

2002 Existing: Existing traffic and roadway conditions in year 2002.

2020 No-Build Scenario: No-Build is the term used to describe what would be expected to happen by the year 2020 if the Region builds only the currently funded projects. The currently funded projects for the I-5 Transportation and Trade Partnership project included: construction of Interstate Max light rail from the Rose Garden to the Expo Center in Portland that was completed and opened in 2004; widening of I-5 to three lanes in each direction between 99th and Main in Vancouver, which is currently under construction; and other transit and highway projects outside the I-5 Corridor that have funding for construction.

2020 Build Scenario: I-5's existing six lanes crossing the Columbia River would be replaced or supplemented with up to ten lanes.

Toll Free: No tolls would be charged.

Tolled: Tolls would be charged for all vehicles crossing the Columbia River on either I-5 or I-205 depending on the tolling scenario.

Toll I-5 Only Scenario: Tolls would be collected in both directions on I-5.

Toll I-5 and I-205 Scenario: Tolls would be collected in one direction on I-5 and in the same direction on I-205. Tolls could be collected either Northbound or Southbound.