



**Washington State
Department of Transportation**
Paula J. Hammond, P.E.
Secretary of Transportation

Southwest Region
11018 Northeast 51st Circle
P.O. Box 1709
Vancouver, WA 98668-1709
360-905-2000 / Fax 360-905-2222
TTY: 1-800-833-6388
www.wsdot.wa.gov

February 15, 2011

American Construction Co., Inc.
1501 Taylor Way
Tacoma, WA 98421-4100

Contract 8078, I-5, Columbia River Bridge
Temporary Pile Test Program
WA 0.3 to OR MP 308.0
State Project
Serial Letter No. 18

RE: Change Order No. 2 – UHMW Rollers Credit

Gentlemen:

Enclosed for your review and signature, please find Change Order No. 2. This change order allows the use of Ultra High Molecular Weight (UHMW) Polyethylene in lieu of the contract specified AASHTO Grade 60 Neoprene for fabrication of rollers.

This change order adds one new lump sum item, "CO2 UHMW Roller Credit" in the amount of -\$800.00, which shall be considered full payment to the State for allowing the material specification change.

Contract time is not affected by this change order.

Please sign and return the Change Order by February 25, 2011, for further processing.

If there are any questions, please contact Keith Daly at (360) 816-8870.

Sincerely,

Frank Green, P.E.
CRC Structures Engineering Manager

KAD:np
Enclosure

cc: Document Control
M. Degenhart
N. Peppers

WASHINGTON STATE DEPARTMENT OF TRANSPORTATION CHANGE ORDER

DATE: 02/14/11
Page 1 of 4

CONTRACT NO: 008078 **FEDERAL AID NO:**
CONTRACT TITLE: I-5, COLUMBIA RIVER BRIDGE TEMPORARY PILE TEST PRO
CHANGE ORDER NO: 2 UHMW ROLLERS - CREDIT

PRIME CONTRACTOR: 910562492 AMERICAN CONSTRUCTION CO., INC.
 1501 TAYLOR WAY
 TACOMA WA 98421-4100

Ordered by Engineer under the terms of Section 1-04.4 of the Standard Specifications

Change proposed by Contractor

ENDORSED BY: <hr/> CONTRACTOR <hr/> DATE	SURETY CONSENT: <hr/> ATTORNEY IN FACT <hr/> DATE
-----------------------------------------------------------------------------	--------------------------------------------------------------------------------------

ORIGINAL CONTRACT AMOUNT: 811,204.00
CURRENT CONTRACT AMOUNT: 811,204.00
ESTIMATED NET CHANGE THIS ORDER: -800.00
ESTIMATED CONTRACT TOTAL AFTER CHANGE: 810,404.00

Approval Required: Region Olympia Service Center Local Agency

<input type="checkbox"/> APPROVAL RECOMMENDED <input type="checkbox"/> EXECUTED <hr/> PROJECT ENGINEER <hr/> DATE	EXECUTED: <hr/> STATE CONSTRUCTION ENGINEER <hr/> DATE
<input type="checkbox"/> APPROVAL RECOMMENDED <input type="checkbox"/> EXECUTED REGIONAL ADMIN: <hr/> BY: <hr/> DATE	OTHER APPROVAL WHEN REQUIRED <hr/> SIGNATURE DATE <hr/> REPRESENTING

**WASHINGTON STATE
DEPARTMENT OF TRANSPORTATION
CHANGE ORDER**

DATE: 02/14/11
Page 2 of 4

CONTRACT NO: 008078

CHANGE ORDER NO: 2

All work, materials, and measurements to be in accordance with the provisions of the Standard Specifications and Special Provisions for the type of construction involved.

This contract is revised as follows:

You are ordered to perform the following described work upon receipt of an approved copy of this change order:

DESCRIPTION

This change order allows the Contractor to substitute Ultra High Molecular Weight (UHMW) Polyethylene in lieu of the contract specified AASHTO Grade 60 Neoprene for rollers as shown on sheet 4 of 4 of this change order.

MEASUREMENT AND PAYMENT

The new lump sum item "CO2 UHMW Roller Credit" in the amount of -\$800.00, shall be considered full and final credit to the State for the change in the contract specifications.

CONTRACT TIME

Working days are not affected by this change order.

**WASHINGTON STATE
DEPARTMENT OF TRANSPORTATION
CHANGE ORDER**

DATE: 02/14/11
Page 3 of 4

CONTRACT NO: 008078	CHANGE ORDER NO: 2
----------------------------	---------------------------

ITEM NO	GROUP NO	STD ITEM	ITEM DESCRIPTION	UNIT MEASURE	UNIT PRICE	EST QTY CHANGE	EST AMT CHANGE
1001	01		CO2 UHMW ROLLER CREDIT	L.S.	-400.00	-400.00	-400.00
1001	02		CO2 UHMW ROLLER CREDIT	L.S.	-400.00	-400.00	-400.00

-800.00
=====

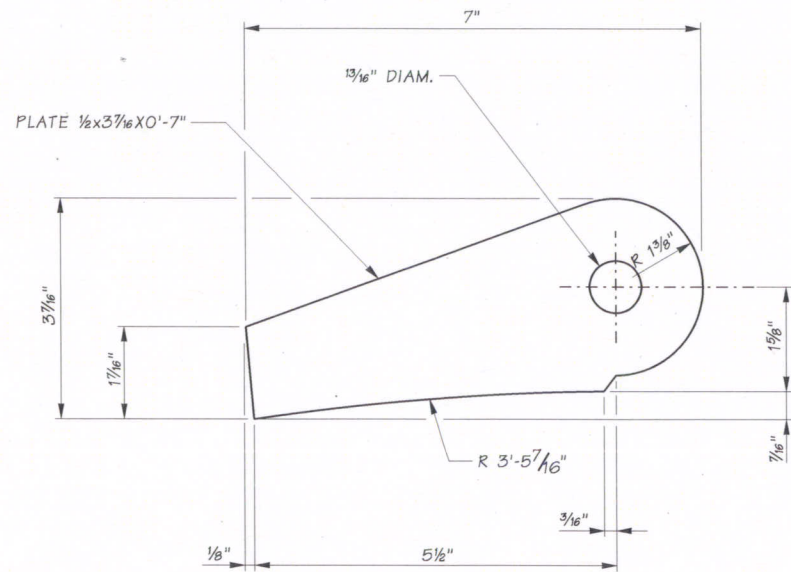

1 **DETAIL**
 TYPICAL HINGE PLATES
 MATERIAL: AL 6061-T6

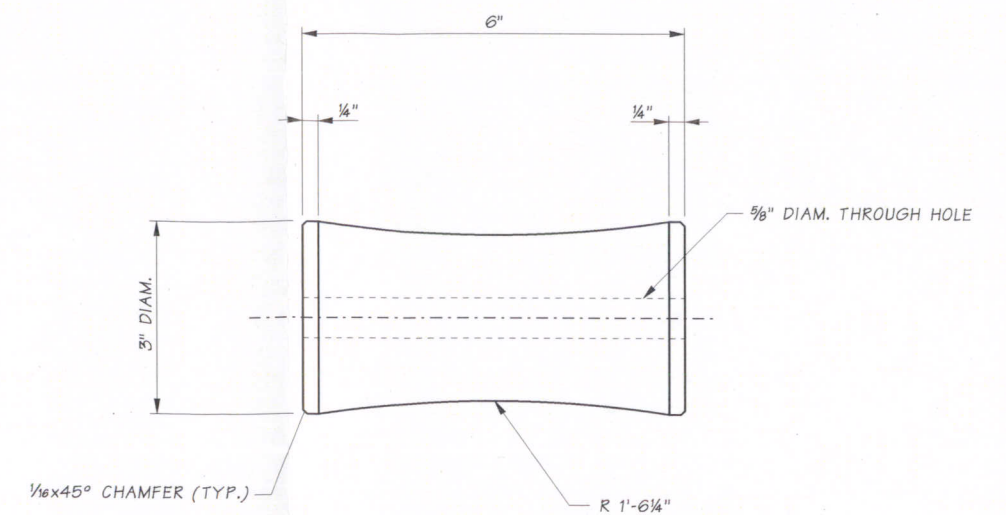
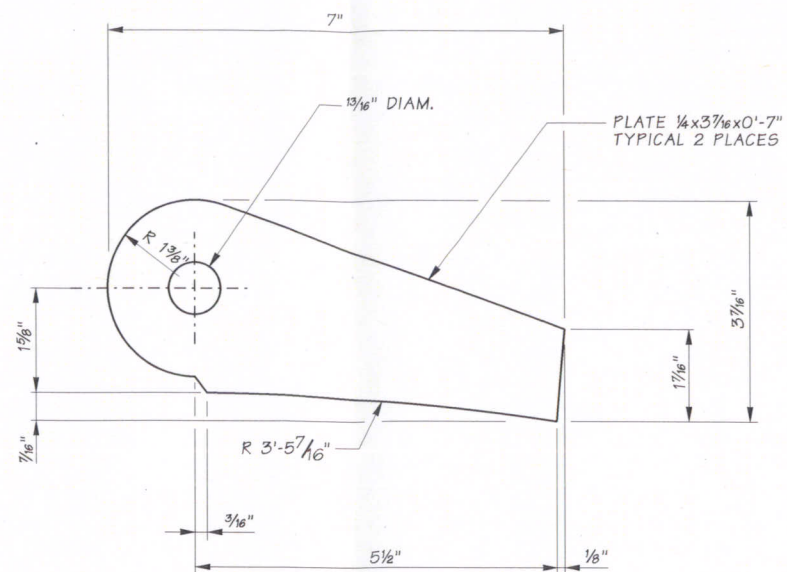

2 **DETAIL**
 TYPICAL ROLLER
 MATERIAL: ULTRA HIGH MOLECULAR WEIGHT POLYETHYLENE

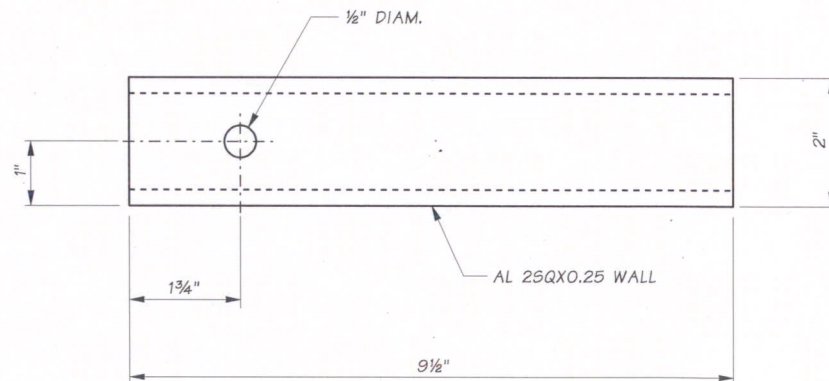

3 **DETAIL**
 TYPICAL ARM GUIDE

Contract 8078
 Change Order No. 2
 Sheet 4 of 4

FILE NAME	c:\aawork\pw_work\crc\burke\dms00922\CRC_Pile_Driving_Sheet10.dgn			REGION NO.	STATE	FED.AID PROJ.NO.			I-5 COLUMBIA RIVER BRIDGE TEMPORARY PILE TEST PROGRAM	Ref. Sht. Number
TIME	3:29:48 PM			10	WASH					ND6
DATE	1/27/2011									SHEET
PLOTTED BY	burkej									10
DESIGNED BY	J. SCHUFREIDER									OF
ENTERED BY	J. BURKE									12
CHECKED BY	J. SCHUFREIDER									SHEETS
PROJ. ENGR.	F. GREEN	CHANGE ORDER #2 - MODIFIED MATERIAL	01/24/2011	FG						
REGIONAL ADM.	D. WAGNER	REVISION	DATE	BY	C8078	XL3604				