

**WASHINGTON STATE  
DEPARTMENT OF TRANSPORTATION  
CHANGE ORDER**

DATE: 02/14/11  
Page 1 of 4

CONTRACT NO: 008078  
 CONTRACT TITLE: I-5, COLUMBIA RIVER BRIDGE TEMPORARY PILE TEST PRO  
 CHANGE ORDER NO: 2 UHMW ROLLERS - CREDIT

FEDERAL AID NO:

PRIME CONTRACTOR: 910562492 AMERICAN CONSTRUCTION CO., INC.  
 1501 TAYLOR WAY  
 TACOMA WA 98421-4100

**RECEIVED**  
 MAR 11 2011  
 Columbia River Crossing

- ( ) Ordered by Engineer under the terms of Section 1-04.4 of the Standard Specifications  
 (X) Change proposed by Contractor

|  |   |
|--|---|
| <p>ENDORSED BY:</p> <p><i>Kevin Culbert</i></p> <p>CONTRACTOR Kevin Culbert, Vice-President</p> <p>February 22, 2011</p> <p>DATE</p> | <p>SURETY CONSENT:</p> <p><b>PROCESSED</b> HQ _____</p> <p>ATTORNEY IN FACT SWR 3-10-11</p> <p><i>J. Lieber</i></p> <p>DATE</p> |
|--|---|

ORIGINAL CONTRACT AMOUNT: 811,204.00  
 CURRENT CONTRACT AMOUNT: 811,204.00  
 ESTIMATED NET CHANGE THIS ORDER: -800.00  
 ESTIMATED CONTRACT TOTAL AFTER CHANGE: 810,404.00

Approval Required: ( ) Region (X) Olympia Service Center ( ) Local Agency

|   |   |
|---|---|
| <p>( ) APPROVAL RECOMMENDED (X) EXECUTED</p> <p><i>Franklin Green</i></p> <p>PROJECT ENGINEER</p> <p>3/9/11</p> <p>DATE</p> | <p>EXECUTED:</p> <p>STATE CONSTRUCTION ENGINEER</p> <p>DATE</p>               |
| <p>( ) APPROVAL RECOMMENDED ( ) EXECUTED</p> <p>REGIONAL ADMIN: D. Wagner</p> <p>BY:</p> <p>DATE</p>                        | <p>OTHER APPROVAL WHEN REQUIRED</p> <p>SIGNATURE DATE</p> <p>REPRESENTING</p> |

WASHINGTON STATE  
DEPARTMENT OF TRANSPORTATION  
CHANGE ORDER

DATE: 02/14/11  
Page 2 of 4

CONTRACT NO: 008078

CHANGE ORDER NO: 2

All work, materials, and measurements to be in accordance with the provisions of the Standard Specifications and Special Provisions for the type of construction involved.

This contract is revised as follows:

You are ordered to perform the following described work upon receipt of an approved copy of this change order:

DESCRIPTION

This change order allows the Contractor to substitute Ultra High Molecular Weight (UHMW) Polyethylene in lieu of the contract specified AASHTO Grade 60 Neoprene for rollers as shown on sheet 4 of 4 of this change order.

MEASUREMENT AND PAYMENT

The new lump sum item "CO2 UHMW Roller Credit" in the amount of -\$800.00, shall be considered full and final credit to the State for the change in the contract specifications.

CONTRACT TIME

Working days are not affected by this change order.

**WASHINGTON STATE  
DEPARTMENT OF TRANSPORTATION  
CHANGE ORDER**

DATE: 02/14/11  
Page 3 of 4

CONTRACT NO: 008078 CHANGE ORDER NO: 2

| ITEM NO | GROUP NO | STD ITEM | ITEM DESCRIPTION       | UNIT MEASURE | UNIT PRICE | EST QTY CHANGE | EST AMT CHANGE |
|---------|----------|----------|------------------------|--------------|------------|----------------|----------------|
| ✓ 1001  | 015 01   |          | CO2 UHMW ROLLER CREDIT | L.S.         | -400.00    | -400.00        | -400.00        |
| ✓ 1001  | 02       |          | CO2 UHMW ROLLER CREDIT | L.S.         | -400.00    | -400.00        | -400.00        |

-----  
-800.00  
-----

**ENTERED IN CAPS**

IN SOUTHWEST REGION

BY J. Lelver DATE 3-10-11

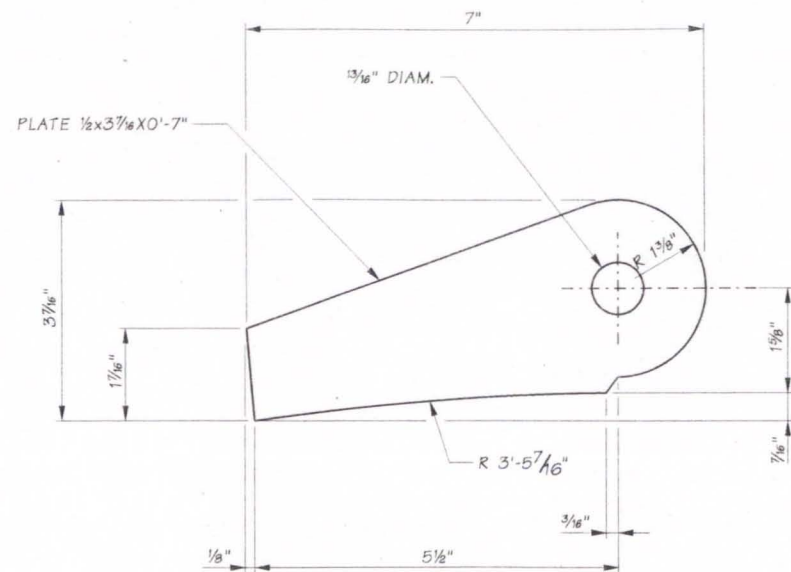

1  
-  
DETAIL  
TYPICAL HINGE PLATES  
MATERIAL: AL 6061-T6

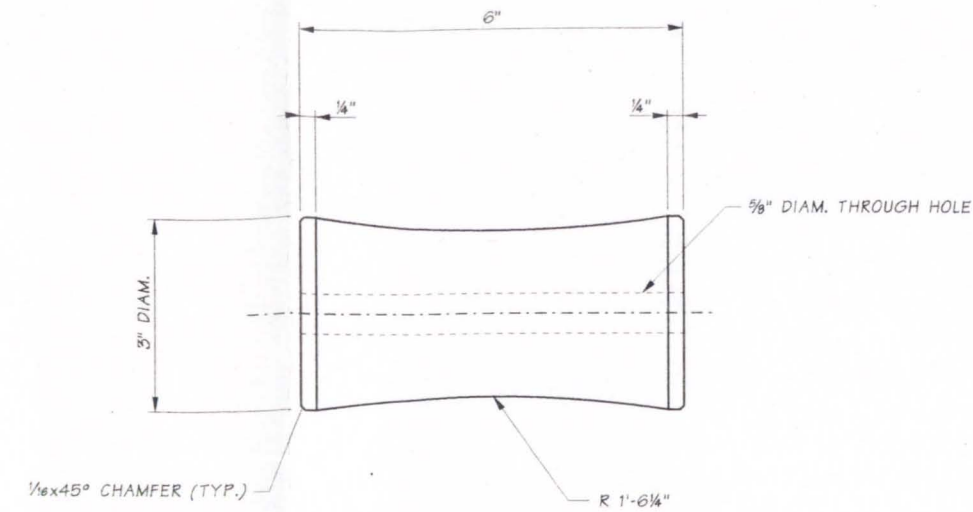
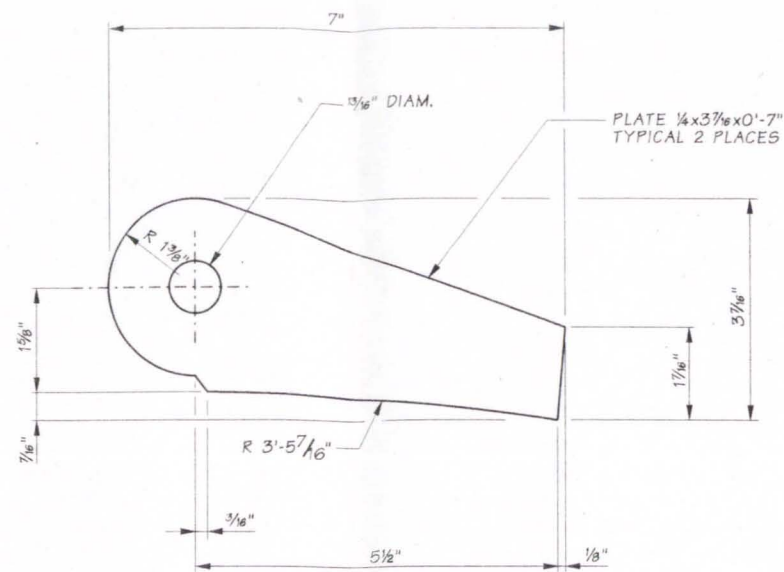

2 2  
ND2 ND3  
DETAIL  
TYPICAL ROLLER  
MATERIAL: ULTRA HIGH MOLECULAR WEIGHT POLYETHYLENE

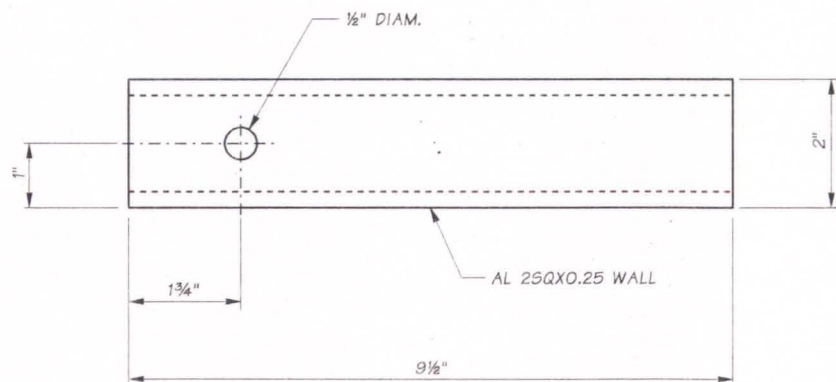

3 3  
ND2 ND3  
DETAIL  
TYPICAL ARM GUIDE

Contract 8078  
Change Order No. 2  
Sheet 4 of 4

|                  |   |                                     |            |
|------------------|---|-------------------------------------|------------|
| FILE NAME        | c:\aawork\pw_work\crc\burke\dms00922\CRC_Pile_Driving_Sheet10.dgn |                                     |            |
| TIME             | 3:29:48 PM  |                                     |            |
| DATE             | 1/27/2011   |                                     |            |
| PLOTTED BY       | burkej  |                                     |            |
| DESIGNED BY      | J. SCHUFREIDER  |                                     |            |
| ENTERED BY       | J. BURKE  |                                     |            |
| CHECKED BY       | J. SCHUFREIDER  |                                     |            |
| PROJ. ENGR.      | F. GREEN  | CHANGE ORDER #2 - MODIFIED MATERIAL | 01/24/2011 |
| REGIONAL ADM.    | D. WAGNER   | REVISION                            | DATE       |
| REGION NO.       | 10  | STATE                               | WASH       |
| JOB NUMBER       | 10X314  |                                     |            |
| CONTRACT NO.     | C8078   |                                     |            |
| FED.AID PROJ.NO. | XL3604  |                                     |            |
| LOCATION NO.     | XL3604  |                                     |            |

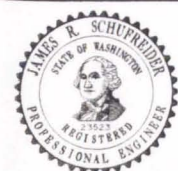

P.E. STAMP BOX



P.E. STAMP BOX

I-5  
COLUMBIA RIVER BRIDGE  
TEMPORARY PILE TEST PROGRAM  
NOISE ATTENUATION DETAIL 2

Ref. Sht. Number  
ND6  
SHEET 10 OF 12 SHEETS