

# COLUMBIA RIVER BRIDGE TECHNICAL SCREENING STUDY

Final Report

December 2008

---



## **Title VI**

The Columbia River Crossing project team ensures full compliance with Title VI of the Civil Rights Act of 1964 by prohibiting discrimination against any person on the basis of race, color, national origin or sex in the provision of benefits and services resulting from its federally assisted programs and activities.

## **Americans with Disabilities Act (ADA) Information**

If you would like copies of this document in an alternative format, please call the Columbia River Crossing project office at (360) 737-2726 or (503) 256-2726. Persons who are deaf or hard of hearing may contact CRC using Telecommunications Relay Service by dialing 7-1-1.

¿Habla usted español? La información en esta publicación se puede traducir para usted. Para solicitar los servicios de traducción favor de llamar al (503) 731-3490.

# TABLE OF CONTENTS

---

<b>1. EXECUTIVE SUMMARY</b> .....	<b>1-1</b>
<b>2. INTRODUCTION</b> .....	<b>2-1</b>
<b>3. BRIDGE TYPES AND CONFIGURATIONS</b> .....	<b>3-1</b>
<b>4. SCREENING PROCESS</b> .....	<b>4-1</b>
<b>5. TIER 1 SCREENING</b> .....	<b>5-1</b>
5.1 Navigational Clearance .....	5-1
5.2 Aviation Clearance.....	5-1
5.3 Technical Suitability .....	5-2
5.4 Tier 1 Screening Results.....	5-2
<b>6. TIER 2 SCREENING</b> .....	<b>6-1</b>
6.1 Performance Attributes .....	6-1
6.1.1 In-Water Work Impacts.....	6-1
6.1.2 Structural Complexity .....	6-1
6.1.3 Aesthetic Opportunity .....	6-1
6.1.4 Maintainability.....	6-2
6.1.5 Project Schedule .....	6-2
6.1.6 Operational Reliability .....	6-2
6.2 Cost Attributes .....	6-2
6.3 Relative Importance of Attributes .....	6-2
6.4 Effect of Configuration.....	6-4
6.5 Discussion of Bridge Types.....	6-5
6.5.1 Concrete Segmental Girder (Three-Bridge) .....	6-5
6.5.2 Haunched Concrete Box Girder with Concrete I-Girder Drop-In Spans (Three-Bridge) .....	6-6
6.5.3 Concrete Segmental Girder (Stacked) .....	6-6
6.5.4 Steel I-Girder (Three-Bridge).....	6-6
6.5.5 Steel Box Girder (Three-Bridge).....	6-6
6.5.6 Open Web Box Girder (Stacked).....	6-7
6.5.7 Extradosed (Three-Bridge).....	6-7
6.5.8 Deck Truss (Three-Bridge).....	6-7
6.5.9 Suspended Frame.....	6-7
6.5.10 Deck Truss (Stacked).....	6-7
6.6 Tier 2 Screening Results.....	6-8
6.7 Survey.....	6-15
<b>7. CONCLUSION</b> .....	<b>7-1</b>

## List of Figures

Figure 6-1. Relative Importance of Performance Attributes .....	6-3
Figure 6-2. Relative Importance of Cost Attributes.....	6-3
Figure 6-3. Tier 2 Performance Attribute Scoring.....	6-9
Figure 6-4. Tier 2 Cost Attribute Scoring.....	6-11
Figure 6-5. Tier 2 Screening Results.....	6-13
Figure 6-6. Tier 2 Screening Results for the Three-Bridge Configuration .....	6-14
Figure 6-7. Tier 2 Screening Results for the Two-Bridge Configuration .....	6-14

## List of Tables

Table 2-1. Screening Study Participants and Panel Members .....	2-2
Table 3-1. Bridge Types Considered.....	3-2
Table 5-1. Performance Requirements for Tier 1 Screening .....	5-1
Table 5-2. Tier 1 Screening Results.....	5-2
Table 6-1. Performance Attributes for Tier 2 Screening .....	6-1
Table 6-2. Cost Attributes for Tier 2 Screening .....	6-2
Table 6-3. Configuration Comparison with Respect to Performance Attributes .....	6-4
Table 6-4. Configuration Comparison with Respect to Cost Attributes.....	6-5
Table 6-5. Tier 2 Performance Attribute Scoring.....	6-8
Table 6-6. Tier 2 Cost Attribute Scoring .....	6-10
Table 6-7. Tier 2 Value Indices .....	6-12

## Appendices

Appendix A Bridge Type Sketches

Appendix B Performance and Cost Attribute Voting Scales

# ACRONYMS

---

AHP	Analytic Hierarchy Process
CRD	Columbia River Datum
FAA	Federal Aviation Administration
LRT	Light Rail Transit
MUP	Multi-Use Path
PDX	Portland International Airport

**This page left blank intentionally.**

# 1. Executive Summary

---

The replacement bridges crossing the Columbia River will be the centerpiece of the Columbia River Crossing Project. These bridges represent the single largest capital expenditure for the project and will be designed to last for 150 years. Given the stature and longevity of the proposed bridges, a rigorous type selection process is in order.

The type selection process consists of a technical screening and an aesthetic screening which are components of the formal type study. The combination of the screening efforts will facilitate the development of alternative(s) that are appropriate for this project. The last step in the type selection process is the formal type study. The formal type study will develop these alternative(s) through additional engineering and aesthetic development to arrive at a recommended alternative(s) and associated construction cost estimates.

The technical screening study initiates the type selection process by determining what bridge types are technically appropriate. The technical screening study consists of two phases. The first phase (tier 1 screening) determines which bridge types have the technical merit to warrant further consideration. Bridge types having technical merit are ranked in the second phase (tier 2 screening).

The technical screening study identified 24 bridge types for consideration. The tier 1 screening narrowed that list of bridge types to ten. The tier 2 screening evaluated and ranked the remaining ten bridge types. All ten of the bridge types advanced from the tier 1 screening will be considered further in the type study process. However, the value indices identified a preference for the concrete segmental girder bridge type for both configurations.

**This page left blank intentionally.**



## 2. Introduction

---

The replacement bridges crossing the Columbia River will be the centerpiece of the Columbia River Crossing Project. These bridges represent the single largest capital expenditure for the project and will be designed to last for 150 years. Given the stature and longevity of the proposed bridges, a rigorous type selection process is in order.

The type selection process consists of a technical screening and an aesthetic screening which are components of the formal type study. The combination of the screening efforts will facilitate the development of alternative(s) that are appropriate for this project. The last step in the type selection process is the formal type study. The formal type study will develop these alternative(s) through additional engineering and aesthetic development to arrive at a recommended alternative(s) and associated construction cost estimates.

The technical screening study initiates the type selection process by determining what bridge types are technically appropriate. The technical screening study consists of two phases. The first phase (tier 1 screening) determines which bridge types have the technical merit to warrant further consideration. Bridge types having technical merit are ranked in the second phase (tier 2 screening).

Seventeen professionals participated in the technical screening study. The voting panel was comprised of twelve bridge engineers. The remaining five professionals provided project background and agency oversight. Table 2-1 lists the Screening Study participants.

**Table 2-1. Screening Study Participants and Panel Members**

<b>Participant</b>	<b>Affiliation</b>
Bruce Johnson	ODOT State Bridge Engineer – Panel Member
Craig Shike	ODOT Bridge Engineer – Panel Member
Jugesh Kapur	WSDOT State Bridge Engineer – Panel Member
Tim Moore	WSDOT Bridge Engineer – Panel Member
Shoukry Elnahal	FHWA Resource Center – Panel Member
Barry Brecto	FHWA – Panel Member
John Buchheit	Gannet Fleming (representing FTA) – Panel Member
Rod Miller	Gannet Fleming (representing FTA) – Panel Member
John Clark	Independent Consultant – Panel Member
Steve Thoman	Independent Consultant – Panel Member
Rob Turton	CRC Bridge Engineer – Panel Member
Matt Deml	CRC Bridge Engineer – Panel Member
Lynn Rust	CRC Assistant Deputy Project Director
Frank Green	CRC Structures Manager
Laura Peterson	CRC Structures Engineer
John McAvoy	FHWA
Steve Saxton	FTA
Rob Stewart	Value Management Services – Facilitator

### **3. Bridge Types and Configurations**

---

All four bridge genres were considered: cable supported, arch, truss, and girder. Within each of the four genres, multiple bridge types were considered. Furthermore, a three-bridge and/or two-bridge (stacked or suspended) configuration was considered for each bridge type. Twenty-two bridge types were initially identified. Study participants identified two additional bridge types prior to starting the technical screening process.

As indicated above, two different bridge configurations were evaluated: three-bridge and two-bridge. The three-bridge configuration uses three separate bridges to replace the existing Interstate Bridges; one for northbound I-5, one for southbound I-5, and the third bridge for light rail transit (LRT) and a multi-use path (MUP). The stacked configuration uses two bridges; one for northbound I-5 and the other for southbound I-5 with LRT on a lower level. The MUP could be placed on either of the two bridges. The suspended configuration is similar to the stacked, except the LRT and MUP would be suspended between the northbound and southbound I-5 bridges.

Table 3-1 lists all 24 of the bridge types and configurations considered. Sketches and brief descriptions of the bridge types are provided in Appendix A. Bridge types were considered without regard to material type. Common preliminary design values for span to depth ratio, pylon height, arch rise, etc. are shown on the sketches, to aid in the assessment of navigation and aviation impacts. While these general relationships are shown to scale, the primary purpose of the sketches was to facilitate discussion, not to imply how the bridge type would be aesthetically expressed for this project. Panel members agreed that the relationships depicted on the sketches were adequate for assessment of these impacts. Bridge types that are advanced to the formal type study will be further refined to address project specific considerations, be they technical, aesthetic, or otherwise.

**Table 3-1. Bridge Types Considered**

<b>Genre</b>	<b>Three-Bridge</b>	<b>Two-Bridge</b>
<b>Cable Supported</b>	<ul style="list-style-type: none"> <li>▪ Cable Stayed</li> <li>▪ Extradosed</li> <li>▪ Suspension</li> </ul>	<ul style="list-style-type: none"> <li>▪ Cable Stayed</li> <li>▪ Extradosed</li> <li>▪ Suspension</li> <li>▪ Extradosed Suspended*</li> </ul>
<b>Arch</b>	<ul style="list-style-type: none"> <li>▪ Deck Arch</li> <li>▪ Through Arch</li> </ul>	<ul style="list-style-type: none"> <li>▪ Deck Arch</li> <li>▪ Through Arch</li> </ul>
<b>Truss</b>	<ul style="list-style-type: none"> <li>▪ Deck Truss</li> <li>▪ Through Truss</li> </ul>	<ul style="list-style-type: none"> <li>▪ Deck Truss</li> <li>▪ Through Truss</li> </ul>
<b>Girder</b>	<ul style="list-style-type: none"> <li>▪ Concrete I-Girder</li> <li>▪ Concrete Segmental Girder</li> <li>▪ Haunched Concrete Box with I-Girder Drop-In Spans</li> <li>▪ Steel Box Girder</li> <li>▪ Steel I-Girder</li> </ul>	<ul style="list-style-type: none"> <li>▪ Concrete Segmental Girder</li> <li>▪ Open Web Box Girder</li> <li>▪ Steel Box Girder</li> <li>▪ Suspended Frame</li> </ul>

\*Extradosed Suspended is a derivative bridge type that was suggested to allow consideration of a two bridge extradosed configuration similar in nature to the Suspended Frame. (Sketch not developed)

## 4. Screening Process

---

Rob Stewart of Value Management Strategies, Inc. facilitated the technical screening process. Mr. Stewart provided an objective structure that the panel used to consider each bridge type. The technical screening process was divided into two tiers.

The tier 1 screening was conducted by evaluating three critical performance requirements for the initial 24 bridge types. Bridge types either passed or failed the performance requirements. Ten of the original 24 bridge types satisfied the performance requirements. These were advanced to the tier 2 screening that utilized a decision support software package called Decision Lens.

Decision Lens is based on advanced analytical methods designed to support decision makers in structuring decisions, quantifying intangible factors, and evaluating choices in a comprehensive and rational framework.

The underlying methodology, called the Analytic Hierarchy Process (AHP), was first developed by mathematician and decision scientist, Dr. Thomas Saaty, while he was a professor at the Wharton School of Business. His methods have been applied to assist organizations in allocating billions of dollars toward selecting the best projects, vendors, people and organizational strategies. The consistency of the judgments is tracked using the rigorous math analytics behind the AHP to validate the decision process. The software makes use of independent voting consoles whereby each participant inputs their decision data in real time. At each phase of the process, group discussions were held to consider the rationale of the decision makers and improve the common understanding of the objectives.

Six performance attributes and two cost attributes were selected for use in the tier 2 screening process. A pair-wise comparison utilizing AHP was performed to determine the relative importance of the performance attributes and the cost attributes independent of one another. Once the relative importance of the attributes was established, each of the 10 remaining bridge types was numerically rated for each attribute. The performance and cost ratings were then multiplied by the attribute weights and summed to develop performance and cost scores for each bridge type. Sensitivity analyses were then performed to test the consistency and confirm the validity of the voting process and resulting scores.

These performance and cost scores were then used to develop a value index, which is the performance score (P) divided by the cost score (C). The resulting value index for each of the remaining 10 bridge types was then normalized for ease of comparison.

**This page left blank intentionally.**

## 5. Tier 1 Screening

---

The tier 1 screening was performed by evaluating the initial 24 bridge types relative to three critical performance requirements. The performance requirements were identified and agreed to by the panel as defined in the table below. A bridge type must meet all of the performance requirements to advance to the second tier screening.

**Table 5-1. Performance Requirements for Tier 1 Screening**

<b>Performance Requirement</b>	<b>Definition</b>
<b>Navigational Clearance</b>	Bridge must provide a navigational opening that is at least 300 feet wide and 95 feet above 0 CRD.
<b>Aviation Clearance</b>	Bridge must not encroach upon the Pearson Field Part 77 imaginary surfaces and PDX aviation surfaces.
<b>Technical Suitability</b>	Bridge must fall within the footprint as defined within the draft EIS (i.e., alignment); must meet the structural design requirements (i.e., seismic, etc.).

### 5.1 Navigational Clearance

The minimum navigational clearance required for vessels on the Columbia river has been established by the project. This opening is a rectangle having a vertical dimension of 95 feet above elevation 0 feet on the Columbia River Datum (CRD) over a 300-foot width. The sketches in Appendix A show the required navigation opening for each of the bridge types. Bridge types must accommodate the abovementioned navigation opening to advance to the tier 2 screening.

### 5.2 Aviation Clearance

The Columbia River Crossing Project is constrained by imaginary aviation surfaces from Portland International Airport (PDX) and Pearson Field. No structure (including lighting and sign bridges) should encroach on the Part 77 Imaginary Surfaces for PDX or Pearson Field. A violation of either of these Imaginary Surfaces could be deemed a “Hazard to Aviation” by the Federal Aviation Administration (FAA). Additionally, no structure should encroach on the Obstacle Clearance Surfaces for PDX. While all of the proposed bridge types will encroach into the Pearson Field Obstacle Clearance Surfaces, encroaching on the Pearson Field Obstacle Clearance Surfaces is not considered a violation of the aviation clearance performance requirement. However, it is an objective of the project to minimize this encroachment to the greatest extent possible. The sketches in Appendix A show the aviation surfaces in relation to each of the bridge types. Bridge types must not encroach into the aviation surfaces, as described above, to advance to the tier 2 screening.

### 5.3 Technical Suitability

Technical suitability is a subjective assessment of appropriateness of a bridge type by engineers with knowledge and experience in bridges of this nature. This assessment considers the ability of the bridge type to avoid any new impacts other than what was defined in the DEIS and meet the structural design requirements. Avoiding new impacts, other than what was defined in the DEIS, specifically refers to accommodating the horizontally curved alignment. Meeting the structural design requirements specifically refers to designing a bridge within reasonable design and construction risk thresholds (i.e., “should we do it” versus “can we do it”). Any bridge determined not to be technically suitable for the project was dropped from further consideration.

### 5.4 Tier 1 Screening Results

Ten of the original 24 bridge types met the performance requirements. Table 5-2 shows the result of the tier 1 screening. Bridge types in bold advanced to the tier 2 screening.

**Table 5-2. Tier 1 Screening Results**

<b>Alternatives</b>	<b>Navigational Clearance</b>	<b>Aviation Clearance</b>	<b>Technical Suitability</b>	<b>Comments</b>
Cable Stayed (Three-Bridge)	yes	no	yes	Violates all aviation surfaces. Considered suitable, but may be technically challenging due to the curved alignment.
Cable Stayed (Stacked)	yes	no	yes	Violates all aviation surfaces. Considered suitable, but may be technically challenging due to the curved alignment..
Suspension (Three-Bridge)	yes	no	no	Towers would violate PDX Obstacle Clearance Surfaces and Pearson Field Part 77 Imaginary Surfaces. Not technically suitable to build a suspension bridge on a curve.
Suspension (Stacked)	yes	no	no	Towers would violate PDX Obstacle Clearance Surfaces and Pearson Field Part 77 Imaginary Surfaces. Not technically suitable to build a suspension bridge on a curve.
<b>Extradosed (Three-Bridge)</b>	yes	yes	yes	Towers would be very close to the Pearson Field Part 77 Imaginary Surfaces.
Extradosed (Stacked)	yes	no	no	Requires either raising the profile which would violate the Pearson Field Part 77 Imaginary Surfaces or lowering the profile which would violate the navigation opening. Increased loads from the stacked configuration exacerbate the already significant transverse framing requirements due to deck width.
Through Arch (Three-Bridge)	yes	no	no	Violates the Pearson Field Part 77 Imaginary Surfaces. Curved alignment and poor soil conditions are problematic from a design and construction standpoint.
Through Arch (Stacked)	yes	no	no	Violates the Pearson Field Part 77 Imaginary Surfaces. Curved alignment and poor soil conditions are problematic from a design and construction standpoint.
Deck Arch (Three-Bridge)	yes	yes	no	A flatter arch or longer spans could be employed to accommodate the navigation opening. Curved alignment and poor soil conditions are problematic from a design and construction standpoint.



<b>Alternatives</b>	<b>Navigational Clearance</b>	<b>Aviation Clearance</b>	<b>Technical Suitability</b>	<b>Comments</b>
Deck Arch (Stacked)	yes	yes	no	Requires raising the profile of the bridge in order to meet navigational clearances. Curved alignment and poor soil conditions are problematic from a design and construction standpoint.
Through Truss (Three-Bridge)	yes	no	yes	Violates the Pearson Field Part 77 Imaginary Surfaces.
Through Truss (Stacked)	yes	no	yes	Violates the Pearson Field Part 77 Imaginary Surfaces.
<b>Deck Truss (Three-Bridge)</b>	yes	yes	yes	Requires raising the profile of the bridge in order to meet navigation opening.
<b>Deck Truss (Stacked)</b>	yes	yes	yes	Requires raising the profile of the bridge in order to meet navigation opening.
<b>Open Web Box Girder (Stacked)</b>	yes	yes	yes	
<b>Concrete Segmental Girder (Three-Bridge)</b>	yes	yes	yes	
<b>Concrete Segmental Girder (Stacked)</b>	yes	yes	yes	
Concrete I-Girder (Three-Bridge)	no	yes	yes	Could consider for approach spans in conjunction with other bridge types.
<b>Steel Box Girder (Three-Bridge)</b>	yes	yes	yes	
Steel Box Girder (Stacked)	yes	yes	no	Non-redundant, fracture critical, fatigue prone bridge type. Highly susceptible to fire.
<b>Steel I-Girder (Three-Bridge)</b>	yes	yes	yes	
<b>Suspended Frame</b>	yes	yes	yes	Concerns about seismic performance of the suspended frame/system.
Extradosed (Suspended)	yes	no	no	Requires either raising the profile which would violate the Pearson Field Part 77 Imaginary Surfaces or lowering the profile which would violate the navigation opening. Increased loads from the stacked configuration exacerbate the already significant transverse framing requirements due to deck width. Concerns about seismic performance of the suspended frame/system. Poses special technical challenges with transverse structural system and tower heights.
<b>Haunched Concrete Box Girder with Concrete I-Girder Drop-In Spans (Three-Bridge)</b>	yes	yes	yes	Concerns with the curved alignment and I-girders.

**This page left blank intentionally.**

## 6. Tier 2 Screening

---

### 6.1 Performance Attributes

The tier 2 screening evaluated the remaining 10 bridge types advanced from the tier 1 screening. The tier 2 screening used six performance attributes to evaluate the remaining bridge types. Performance attributes were discussed, defined, and agreed to by the screening study participants. Table 6-1 defines these performance attributes.

**Table 6-1. Performance Attributes for Tier 2 Screening**

<b>Performance Attribute</b>	<b>Definition</b>
In-Water Work Impacts	An overall assessment of the impacts relative to the degree and duration of in-water work as it applies to marine traffic and environmental impacts.
Structural Complexity	An overall assessment of the technical complexity of the structural details as it relates to both design and construction:
Aesthetic Opportunity	An assessment of the opportunities for articulating the bridge in an aesthetically pleasing manner. Considers both the ease and diversity of potential aesthetic features.
Maintainability	The long-term maintenance and operations costs. This attribute also includes the ease of maintenance and inspection of the bridge.
Project Schedule	The total time to construct the bridge as measured from today.
Operational Reliability	An assessment of risk related to maintaining operations.

#### 6.1.1 In-Water Work Impacts

In-water work impacts are an assessment of marine traffic and environmental consequences due to construction activities. A marine traffic impact is one that requires temporary relocation or restricted use of the navigation channel. An environmental impact is one that has an adverse effect on marine life. In general, alternatives with a greater impact are expected to be those with more piers in the water and heavier bridges requiring larger foundations.

#### 6.1.2 Structural Complexity

Structural complexity refers to the relative difficulty and familiarity of the design and construction of the bridge. Unusual bridge types and/or configurations typically require a greater level of detail and therefore have a higher degree of structural complexity.

#### 6.1.3 Aesthetic Opportunity

Aesthetic opportunity is an assessment of the potential for aesthetic enhancement for a given bridge type. It is a measure of how a bridge type may be manipulated or sculpted to provide visual enhancement. It is not an assessment of aesthetic value/quality of any specific bridge.

### 6.1.4 Maintainability

Maintainability is an assessment of potential operation and maintenance costs over the life of the bridge. Considerations include inspection access, effort required for inspection, maintenance of additional systems (ventilation, lighting, etc.), potential for repair and/or rehabilitation, and the effects of these activities on operations. Bridges that are simple, common, or familiar should fare better in this category.

### 6.1.5 Project Schedule

Project schedule is an assessment of the time required to design and construct the bridge. Bridge types/configurations that have more bridges and/or more foundations in the water will generally take longer to construct. More complex bridge types will generally take longer to design.

### 6.1.6 Operational Reliability

Operational reliability is an assessment of risk associated with bridge type characteristics and how they may affect operations in emergency scenarios such as accidents, fires, and explosions.

## 6.2 Cost Attributes

Design and construction cost estimates are not available at this stage of project development. However, since some assessment of relative cost is required to determine the value index for each of the bridge types, two cost attributes were identified by the study participants (see Table 6-2). More complex bridge types will generally cost more to design and construct.

**Table 6-2. Cost Attributes for Tier 2 Screening**

Cost Attribute	Definition
Design Cost	The total cost to design the bridge.
Construction Cost	The total capital cost of construction, inclusive of risk.

## 6.3 Relative Importance of Attributes

A pair-wise comparison was performed to determine the relative importance of the performance attributes. Figure 6-1 shows the results of this comparison. Structural complexity, operational reliability, and maintainability were determined to be the three most important performance attributes accounting for approximately 80 percent of the total weight. Aesthetic opportunity, project schedule, and in-water work impacts comprised the remaining 20 percent.

**Figure 6-1. Relative Importance of Performance Attributes**

---

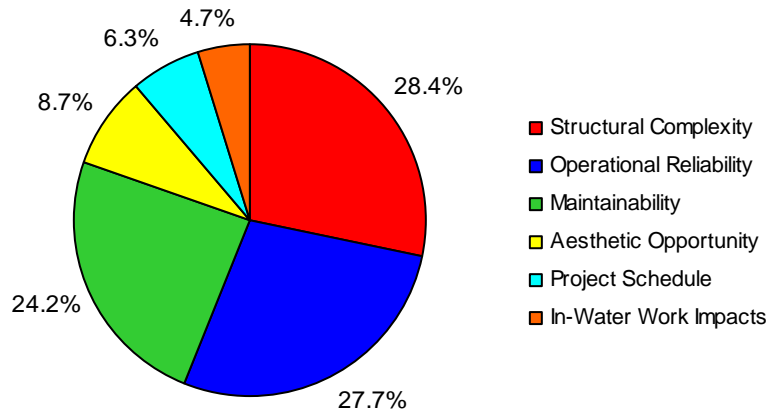
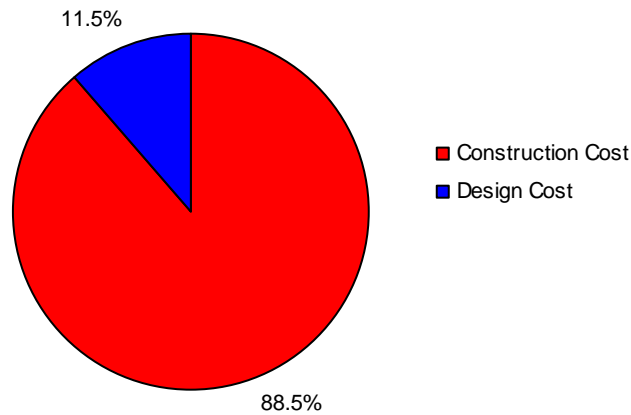

Figure 6-2 shows the relative importance of design and construction cost attributes as determined by the screening study participants. Construction cost was determined to be approximately 90 percent of the total weight.

**Figure 6-2. Relative Importance of Cost Attributes**

---



After determining the relative importance of the performance and cost attributes, study participants created rating scales for all of the attributes. These scales were used to rate the bridge types. The scales are in Appendix B.

## 6.4 Effect of Configuration

The attributes were discussed relative to the bridge configurations without reference to any specific bridge type. For the two-bridge configuration, the suspended bridge types were separated from the stacked bridge types to identify characteristic differences.

Pros and cons of each configuration were discussed with respect to each of the performance and cost attributes defined above. The discussion built consensus among the study participants and the comparison provided a consistent basis for evaluating the effect of configuration on the bridge types (see Table 6-3 and Table 6-4).

**Table 6-3. Configuration Comparison with Respect to Performance Attributes**

Performance Attributes	Bridge Configurations		
	Three-Bridge	Two-Bridge (Stacked)	Two-Bridge (Suspended)
In-Water Work Impacts	Has the greatest in-water impacts because it has the largest foundation footprint.	Smaller foundation footprint, therefore less in-water impacts.	Smaller foundation footprint, therefore less in-water impacts.
Structural Complexity	Complexity of configuration is a function of the bridge type. Sub-structure complexity will be similar for all options.	Structural complexity of superstructure will be greater. For closed bridge types, ventilation issues will add to complexity. Installation of the catenary system for transit will be simpler (i.e., no poles required). Greater risk in unconventional details. Increased mass results in greater seismic forces.	The superstructure complexity would probably be greater for the suspended configuration than the stacked configuration. The suspended structure might be more susceptible to vibration. More likely to be fracture critical. Greater risk in unconventional details. Problematic seismic behavior.
Aesthetic Opportunity	Potential aesthetic concerns due to the effect of the curved alignment and column placement (i.e., parallax). More vertical elements (i.e., columns). Provides better vistas for peds/bikes/transit. Results in visual dissimilarities between the transit and highway bridges.	Depth of superstructure will be greater especially at mid-span (22' vs. 12'). Fewer columns than the three-bridge. Fewer opportunities for view sheds for peds/bikes/transit.	Results in a combination of dissimilar bridge types (i.e., main superstructure vs. suspended superstructure). Fewer columns than the three-bridge. Suspended structure may look like an "add on" feature. Visual discontinuity of profile grade for suspended structure due to differing transit/highway profiles.
Maintainability	Requires greater inspection due to increased overall structural area, however, inspection and maintenance will be conventional.	Inspection may be difficult due to ongoing transit/bike/ped operations within the superstructure. Might be slightly higher than the three-bridge configuration due to additional inspection and operational issues. Higher operation and maintenance costs for transit due to ventilation and lighting.	Similar to stacked. Additional concerns due to dissimilar structure type of the suspended structure. Inspection access will be more challenging. Probably the most expensive to maintain due to potential for fracture critical elements, fatigue, etc.
Project Schedule	Assume all three bridges will be built simultaneously. Greater potential schedule risk due to greater in-water work. May be greater opportunities to shorten schedule by working in parallel.	There would be less substructure to build; however, the construction of the superstructure may be more labor intensive due to its complexity.	There would be less substructure to build; however, this configuration requires the two main bridges to be built before the suspended bridge can be built.

Performance Attributes	Bridge Configurations		
	Three-Bridge	Two-Bridge (Stacked)	Two-Bridge (Suspended)
Operational Reliability	Provides the highest level of redundancy. Allows greater flexibility in detouring traffic during emergency situations. An incident on one bridge is less likely to disrupt operations on the other bridges.	Concerns about incidents and their impact on operations. Emergency access for operations in superstructure is restricted to the ends (in closed box). Maintenance is likely to have impacts on transit operations. The enclosed space (closed box) for transit requires ventilation - mechanical problems could result in operational delays.	Similar to stacked. Better than closed box stacked for emergency access for transit. No ventilation issues. Transit incidents could pose a greater risk by requiring both structures to be closed.

**Table 6-4. Configuration Comparison with Respect to Cost Attributes**

Cost Attributes	Bridge Configurations		
	Three-Bridge	Two Bridge (Stacked)	Two Bridge (Suspended)
Construction Cost	Has the greatest amount of sub-structure work. Increased risks related to foundation construction.	May be less than a similar three-bridge configuration. Decreased risk related to foundation work. Greater risk with the superstructure.	Has reduced substructure work, however, superstructure complexities may reduce some or all of those benefits.
Design Cost	Essentially designing three different bridges.	Designing two bridges but additional design work needed for the superstructure complexities.	Additional design work needed for the superstructure complexities.

## 6.5 Discussion of Bridge Types

The voting process entailed an evaluation of all of the bridge types for each of the performance and cost attributes previously defined. The voting process was open and interactive allowing for discussion and reassessment, thereby ensuring the accountability of the panel members and credibility of the results. Discussions served two purposes: 1) they provided an opportunity to recap the basic characteristics of a given bridge type and 2) they provided an opportunity to resolve variability in the voting when it exceeded expectations. The discussions also allowed for continuous reinforcement of the attribute definitions to promote consistent judgments. The following is a summary of the aforementioned discussions.

### 6.5.1 Concrete Segmental Girder (Three-Bridge)

The three-bridge concrete segmental bridge type is familiar to owners, contractors, and designers. It has a good track record for performance, is easy to maintain, and is a straightforward design. The primary concern with this bridge type is the relatively large number of foundations in the river due to the three-bridge configuration. This bridge type has a low design and construction cost risk due to the engineer and contractor familiarity with the bridge type.

### **6.5.2 Haunched Concrete Box Girder with Concrete I-Girder Drop-In Spans (Three-Bridge)**

The haunched concrete box girder with concrete I-girder drop-in spans bridge type is a combination of commonly used elements. Steel drop-in spans could also be used instead of concrete. Bridges of this type are common, although not in the proposed span lengths or on a curved alignment. The details associated with this design and construction of this bridge type are more complex than a traditional concrete girder bridge. Once constructed, this bridge type is expected to have a low life-cycle cost. In-water work impacts will be greater since this is a three-bridge configuration with shorter spans.

### **6.5.3 Concrete Segmental Girder (Stacked)**

Using a concrete segmental girder in a stacked configuration is uncommon, but not unique. The design and construction of this bridge type is intuitively more difficult than a traditional concrete segmental girder given the need for an internal track support structure and pier diaphragm penetrations for the LRT. Maintainability would also be challenging due to the operational constraints of a shared facility. This bridge type would have less in-water work impacts than a three-bridge configuration.

The greatest concern for this bridge type was operational reliability, specifically as it relates to the potential for and response to emergency scenarios. Additionally, an incident related to one mode (i.e., transit/highway) would likely cause an operational disruption to the shared mode (i.e., highway/transit). Several screening study participants were opposed to this bridge type (closed box) due to the above considerations.

### **6.5.4 Steel I-Girder (Three-Bridge)**

A steel I-girder bridge is among the simplest and most straightforward of the bridge types to design and construct. Concern was expressed over the operational reliability (fatigue) and maintainability (coating maintenance). Due to the variable and overall depth of the girders, inspection access would be difficult and likely require additional inspection access facilities such as walkways. The shorter 400-foot spans and three-bridge configuration will also have greater in-water work impacts than other bridge types. Additionally, temporary support structures in the water may be necessary to erect spans. Steel I-girder bridges have little opportunity for aesthetic expression.

### **6.5.5 Steel Box Girder (Three-Bridge)**

The steel box girder is somewhat simple to design, but more difficult to fabricate than a steel I-girder. Increased fabrication complexity translates into higher costs. As with the steel I-girder bridge type, fatigue and coating maintenance are operational reliability and maintainability concerns respectively. The shorter 400-foot spans and three-bridge configuration will also have greater in-water work impacts than other bridge types. Additionally, temporary support structures in the water may be necessary to erect spans.



### **6.5.6 Open Web Box Girder (Stacked)**

This bridge type is similar to the concrete segmental stacked bridge type, the primary difference being that the webs will be open. Design and construction of the web system raised concerns about structural complexity. In-water work impacts were expected to be low, due to the stacked configuration and 500 foot spans. Two benefits of this bridge type are a reduction in weight (foundation and seismic considerations) and an open environment for shared modes. The open environment relieved some of the concerns regarding transit in a stacked concrete segmental (closed box) bridge type.

### **6.5.7 Extradosed (Three-Bridge)**

While there are extradosed bridges in service overseas, this bridge type is new to the United States. The vertical elements (pylons) and cables of this bridge type offer an aesthetic opportunity that is unique relative to the other remaining bridge types. However, the number of pylons and cable arrays required for three bridges are a concern. Since the pylons are exterior to the deck, the clearance between bridges will need to be increased resulting in the largest overall footprint (alignment and disturbance area). The three-bridge configuration results in increased in-water work impacts. This bridge type also has increased risks associated with a more complex structural system (operational reliability, maintenance, and structural complexity).

### **6.5.8 Deck Truss (Three-Bridge)**

Deck trusses are a well known and extensively used bridge type. Concern was expressed over the operational reliability (fatigue) and maintainability (coating maintenance). This bridge type is considered to have limited aesthetic opportunity (truss framing). The three-bridge configuration results in increased in-water work impacts.

### **6.5.9 Suspended Frame**

The suspended frame is a unique solution in which the shared modes (LRT and MUP) would be suspended between the northbound and southbound highway bridges. The highway bridges are assumed to be segmental concrete girders (see Section 5.5.1). Many of the study participants were concerned with the detailing and performance (seismic) of the connections between the suspended bridge and the highway bridges (structural complexity and maintainability). Emergency access to the suspended facility was also a concern (operational reliability).

### **6.5.10 Deck Truss (Stacked)**

Stacked deck trusses (sometimes referred to as double deck trusses) have been built and are currently in service in the United States. While the open framing relieved some of the concerns regarding transit in a shared facility, concern was expressed over operational reliability (fatigue) and maintainability (coating maintenance). This bridge type is considered to have limited aesthetic opportunity (truss framing). The stacked configuration reduces in-water work impacts.

## 6.6 Tier 2 Screening Results

The performance and cost attributes were used to rate the ten bridge types. Table 6-5 shows the results of the performance attribute ratings for the tier 2 screening. The performance score, listed in the second column, is the sum of each of the performance attribute ratings multiplied by the relative importance of that attribute. The relative importance is shown below each of the performance attributes. Figure 6-3 is a graphical representation of the data presented in Table 6-5.

**Table 6-5. Tier 2 Performance Attribute Scoring**

Bridge Type	Performance Score	In-Water Work Impacts (0.05)	Structural Complexity (0.28)	Aesthetic Opportunity (0.09)	Maintain-ability (0.24)	Project Schedule (0.06)	Operational Reliability (0.28)
Concrete Segmental Girder (Three-Bridge)	0.72	0.45	0.57	0.77	0.92	0.65	0.75
Haunched Concrete Box Girder w/ Concrete I-Girder Drop-In Spans (Three-Bridge)	0.60	0.28	0.60	0.48	0.77	0.36	0.60
Steel I-Girder (Three-Bridge)	0.57	0.44	0.77	0.40	0.40	0.58	0.60
Steel Box Girder (Three-Bridge)	0.54	0.53	0.53	0.62	0.42	0.50	0.63
Extradosed (Three-Bridge)	0.48	0.47	0.20	0.83	0.53	0.34	0.63
Deck Truss (Three-Bridge)	0.46	0.54	0.40	0.47	0.28	0.58	0.63
Concrete Segmental Girder (Stacked)	0.44	0.60	0.32	0.53	0.67	0.66	0.27
Open Web Box Girder (Stacked)	0.44	0.63	0.19	0.67	0.53	0.50	0.48
Deck Truss (Stacked)	0.39	0.70	0.25	0.40	0.28	0.72	0.50
Suspended Frame	0.37	0.57	0.24	0.33	0.40	0.42	0.46

**Figure 6-3. Tier 2 Performance Attribute Scoring**

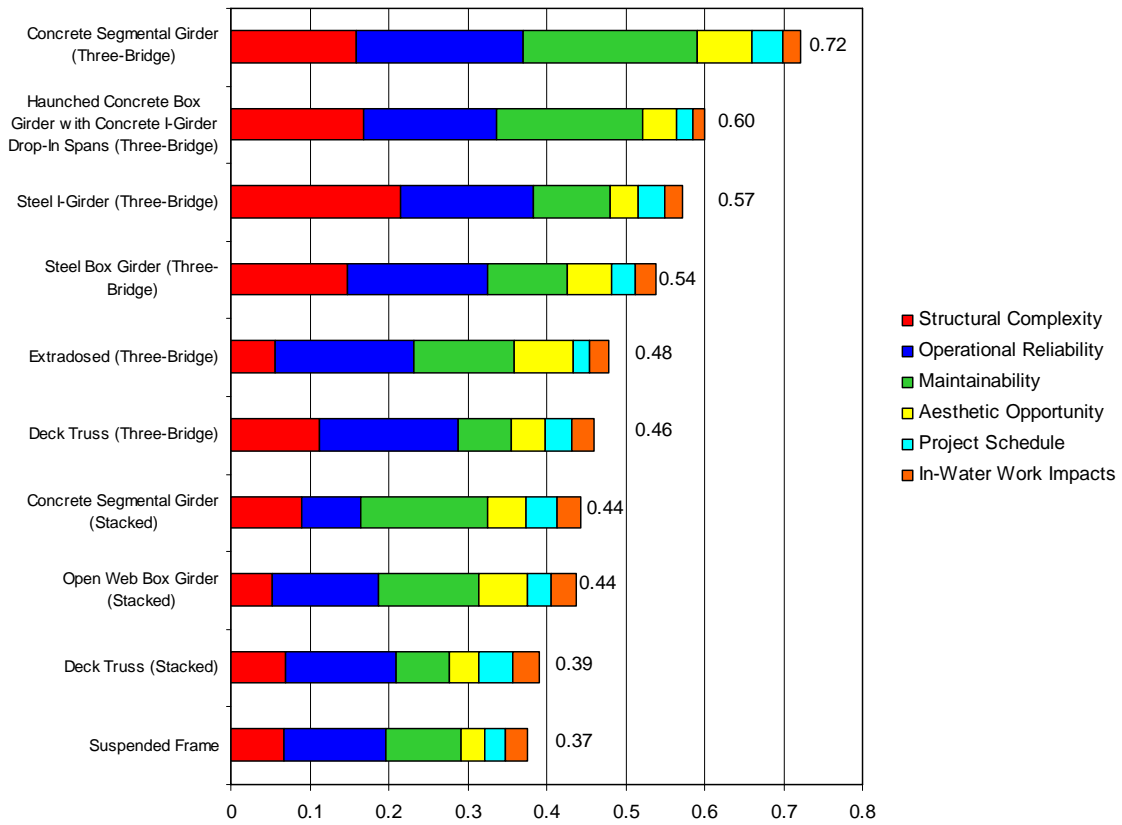
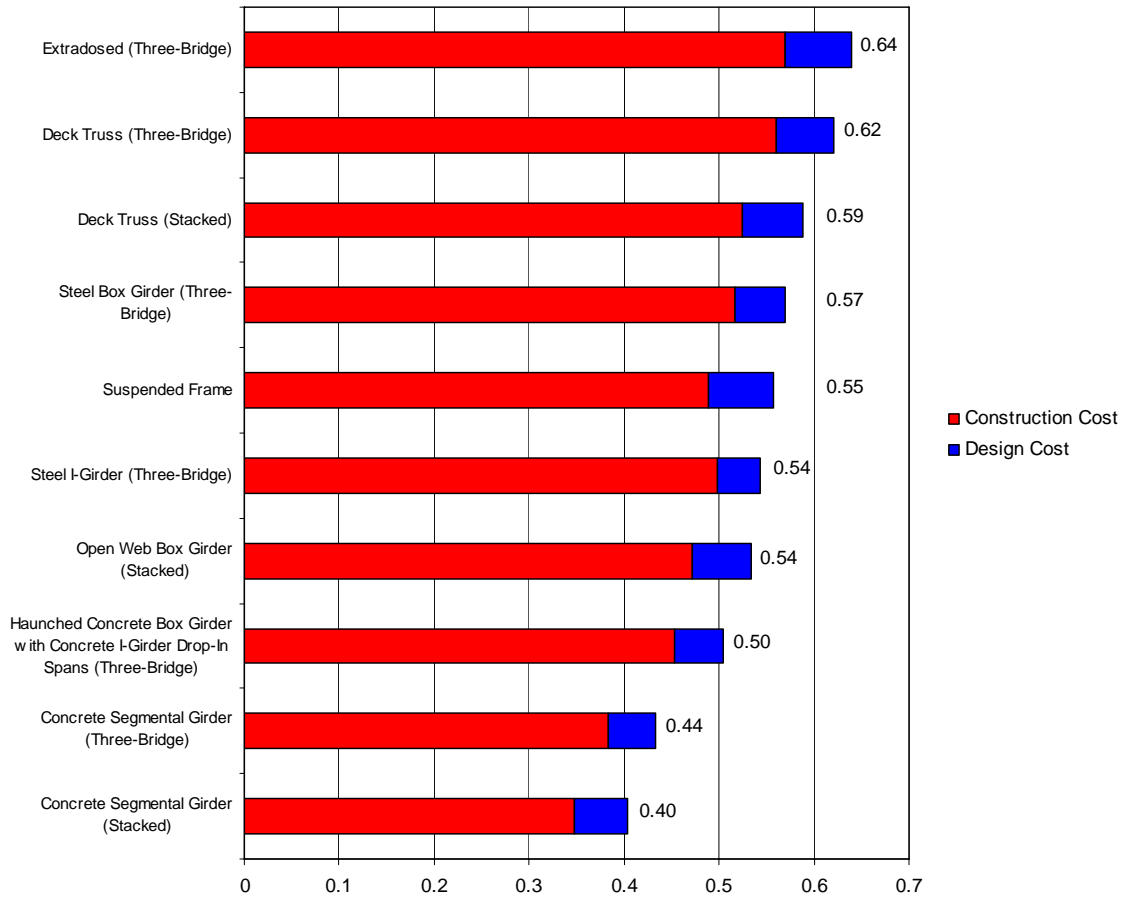

Table 6-6 shows the results of the cost attribute scoring. The cost score, listed in the second column, is the sum of each of the cost attribute ratings multiplied by the relative importance of that attribute. Note that a low cost score corresponds to a lower cost and a high cost score indicates a higher cost. The relative importance is shown below each of the cost attributes in Table 6-6. Figure 6-4 is a graphical representation of the data presented in Table 6-6.

**Table 6-6. Tier 2 Cost Attribute Scoring**

<b>Alternatives</b>	<b>Cost Score</b>	<b>Construction Cost (0.89)</b>	<b>Design Cost (0.11)</b>
Concrete Segmental Girder (Stacked)	0.40	0.39	0.51
Concrete Segmental Girder (Three-Bridge)	0.44	0.43	0.46
Haunched Concrete Box Girder with Concrete I-Girder Drop-In Spans (Three-Bridge)	0.50	0.51	0.46
Open Web Box Girder (Stacked)	0.54	0.53	0.56
Steel I-Girder (Three-Bridge)	0.54	0.56	0.41
Suspended Frame	0.55	0.55	0.61
Steel Box Girder (Three-Bridge)	0.57	0.58	0.48
Deck Truss (Stacked)	0.59	0.59	0.58
Deck Truss (Three-Bridge)	0.62	0.63	0.54
Extradosed (Three-Bridge)	0.64	0.64	0.63

**Figure 6-4. Tier 2 Cost Attribute Scoring**



The value index is the performance score divided by cost score for a given bridge type. The value indices are shown in Table 6-7. Figure 6-5 is a graphical representation of the normalized indices shown in Table 6-7. A higher value index indicates greater value.

**Table 6-7. Tier 2 Value Indices**

<b>Alternatives</b>	<b>Performance Rating ( P )</b>	<b>Cost Rating ( C )</b>	<b>Value Index (P/C)</b>	<b>Normalized Value Index (P/C)</b>
Deck Truss (Stacked)	0.391	0.585	0.668	41%
Suspended Frame	0.374	0.554	0.676	41%
Deck Truss (Three-Bridge)	0.458	0.622	0.736	45%
Extradosed (Three-Bridge)	0.476	0.638	0.746	45%
Open Web Box Girder (Stacked)	0.436	0.536	0.813	49%
Steel Box Girder (Three-Bridge)	0.536	0.569	0.942	57%
Steel I-Girder (Three-Bridge)	0.574	0.543	1.057	64%
Concrete Segmental Girder (Stacked)	0.443	0.405	1.093	66%
Haunched Concrete Box Girder with Concrete I-Girder Drop-In Spans (Three-Bridge)	0.602	0.501	1.200	73%
Concrete Segmental Girder (Three-Bridge)	0.719	0.437	1.645	100%

**Figure 6-5. Tier 2 Screening Results**

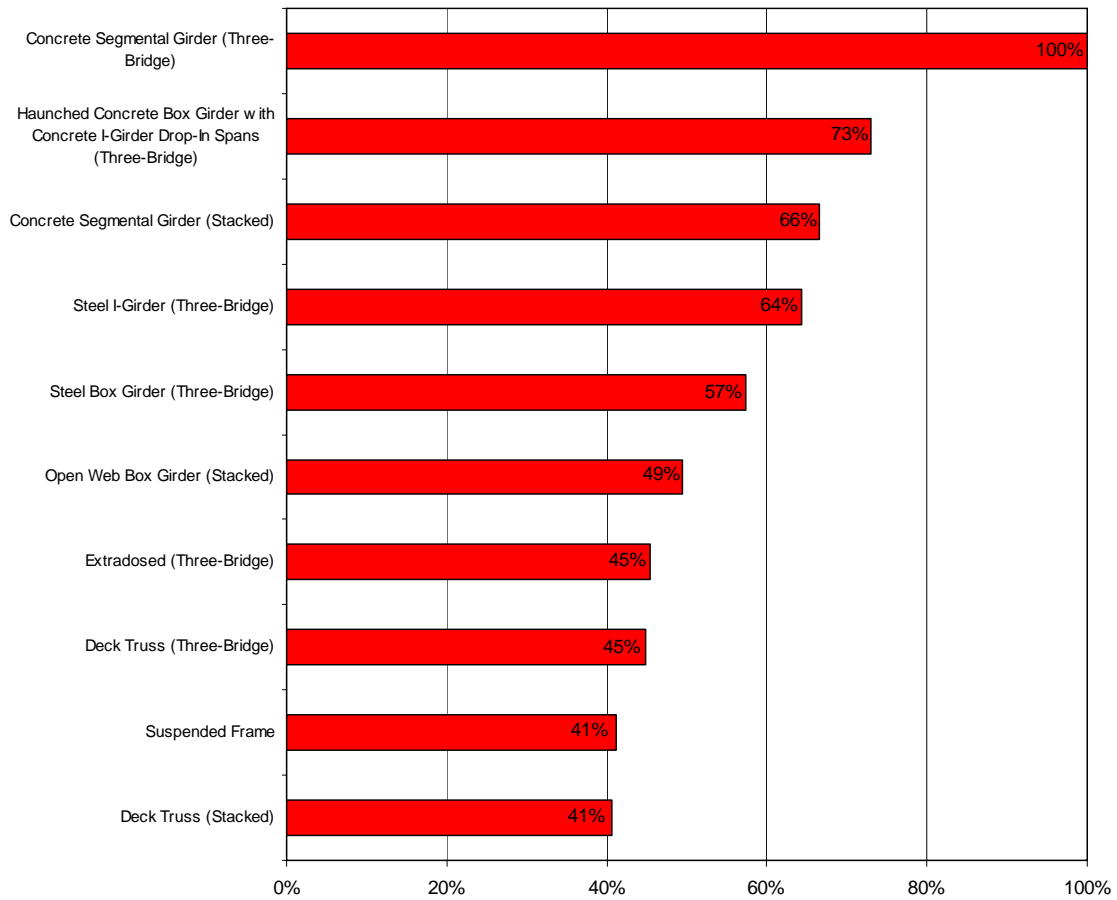

At some point in the project development process, a decision will be made regarding configuration. In order to address this eventuality, the tier 2 screening results were separated by configuration. For this comparison, the value indices for each of the bridge types (Table 6-7) were normalized to the top performer in their respective configuration. Figure 6-6 and Figure 6-7 show the results for the three-bridge and two-bridge configurations, respectively.

**Figure 6-6. Tier 2 Screening Results for the Three-Bridge Configuration**

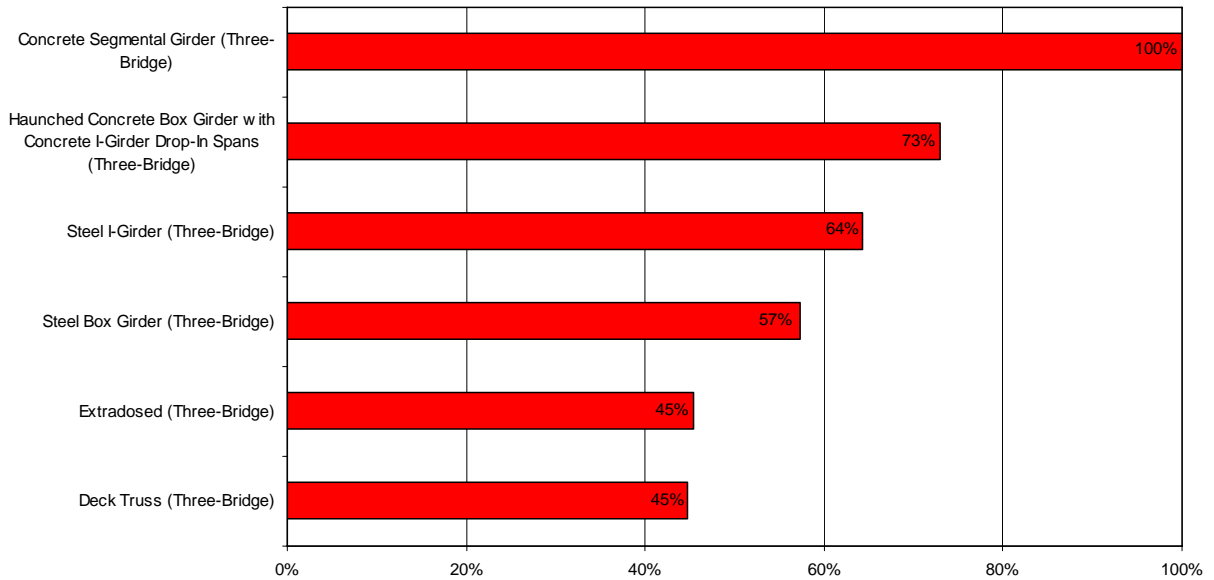

**Figure 6-7. Tier 2 Screening Results for the Two-Bridge Configuration**

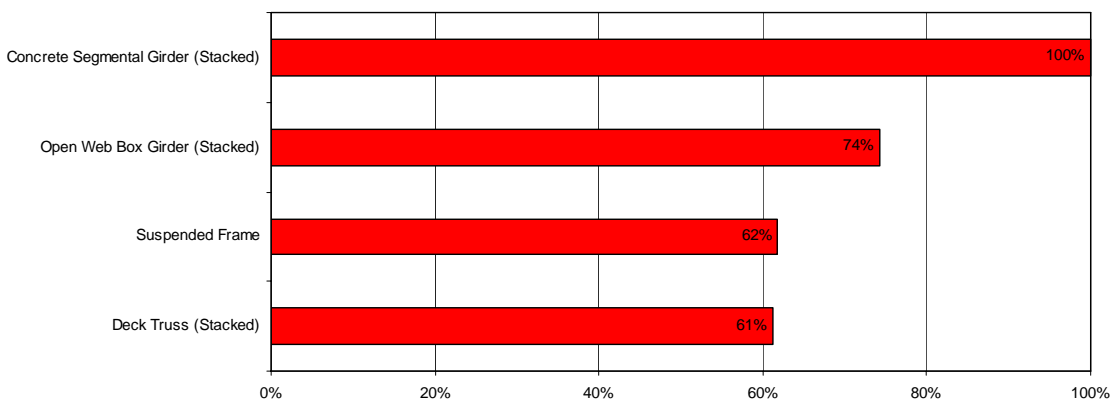



## 6.7 Survey

After the discussions were complete and the value indices were determined, panel members were asked two questions for both the three-bridge and two-bridge configurations:

- Which alternative would you prefer?
- Which alternative would you dismiss?

This survey provided an opportunity for the panel members to state their professional opinions taking into account all workshop discussions (see Section 6.5), their agency's policies, and their own experience.

For the three-bridge configuration, the panel members unanimously preferred a concrete segmental bridge type. The deck truss bridge type received the most dismissal votes followed by the extradosed bridge type for the three-bridge configuration.

The majority of panel members preferred the open web box girder for the two-bridge configuration. The concrete segmental box girder (closed box) received the most dismissal votes followed by the suspended frame for the two-bridge configuration.

The bridge type discussions presented in Section 6.5 contain the basis for the above survey results. It is evident that the benefits of the concrete segmental (three-bridge) and open web box girder (two-bridge) were significant enough that the panel members preferred these bridge types. Additionally, the concerns identified in the discussions were significant enough that much of the group voted to dismiss the bridge types identified above.

**This page left blank intentionally.**

## 7. Conclusion

---

The technical screening study identified 24 bridge types for consideration. The tier 1 screening narrowed that list of bridge types to ten. The tier 2 screening evaluated and ranked the remaining ten bridge types. All ten of the bridge types advanced from the tier 1 screening will be considered further in the type study process. However, the value indices identified a preference for the concrete segmental girder bridge type for both configurations.

**This page left blank intentionally.**

**APPENDIX A**  
**Bridge Type Sketches**

**This page left blank intentionally.**

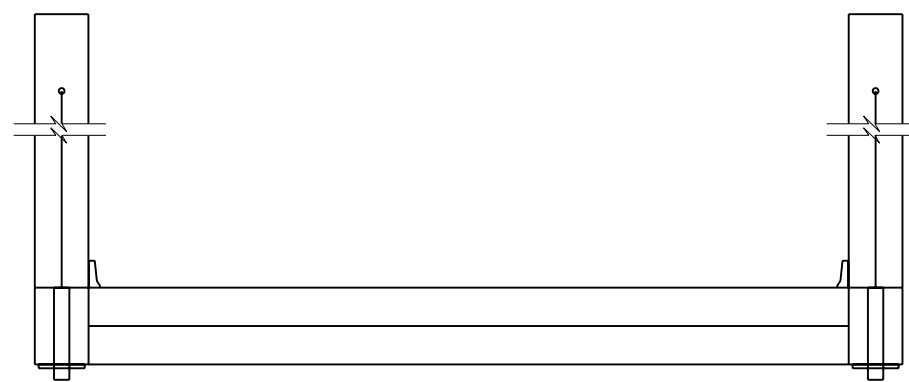
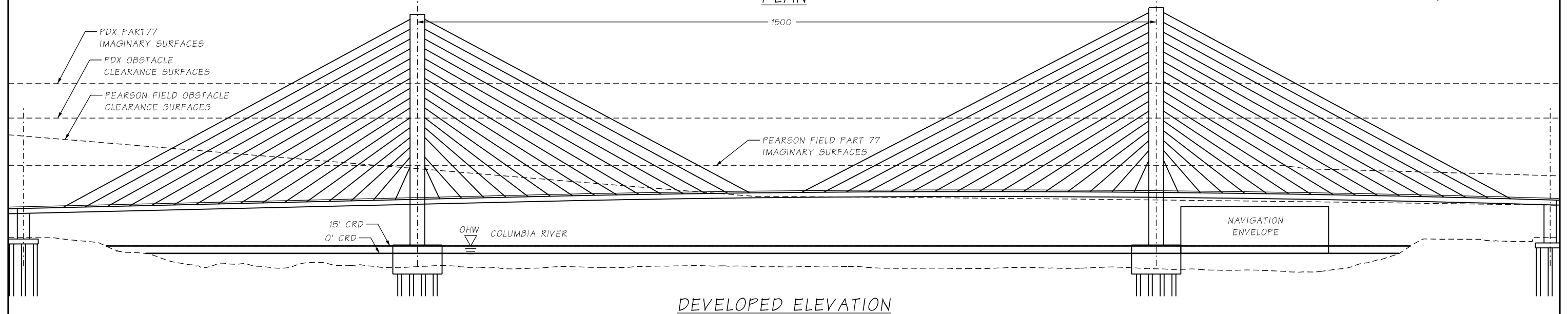
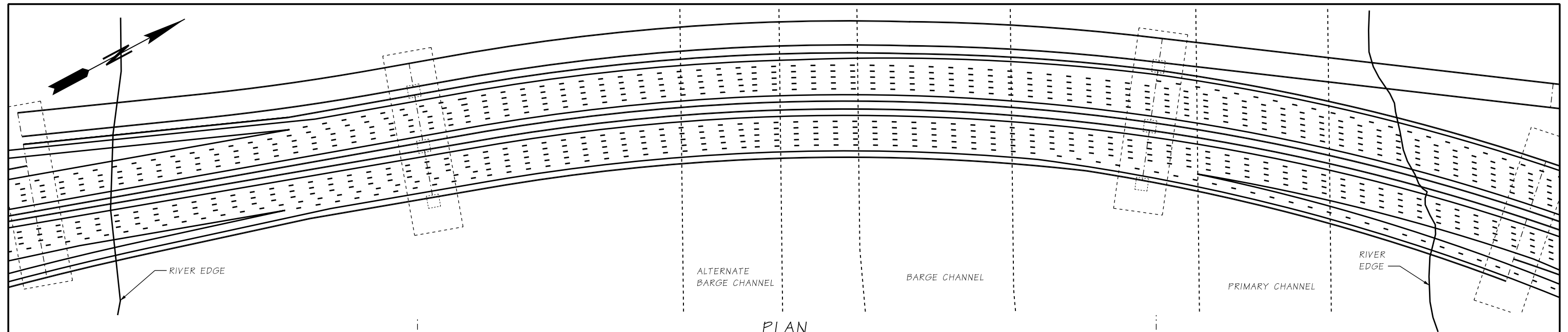

TYPICAL SECTION (3-BRIDGE)

CABLE STAYED

DESCRIPTION

**3-BRIDGE:**  
 Three side-by-side cable stayed bridges. Each bridge has two towers with a 1500-foot main span between the 375-foot tall towers. One bridge carries 1-5 northbound (99 feet wide), one carries 1-5 southbound (99 feet wide), and one carries bike/ped and transit (50 feet wide).

**STACKED:**  
 Two side-by-side cable stayed bridges. Each bridge has two towers with a 1500-foot main span between the 375-foot tall towers. One bridge carries 1-5 northbound and the other carries 1-5 southbound, bike/ped and/or transit is below 1-5. Both bridges are 99 feet wide.

- SKETCH -  
 FOR  
 DISCUSSION ONLY

Columbia River  
**CROSSING**

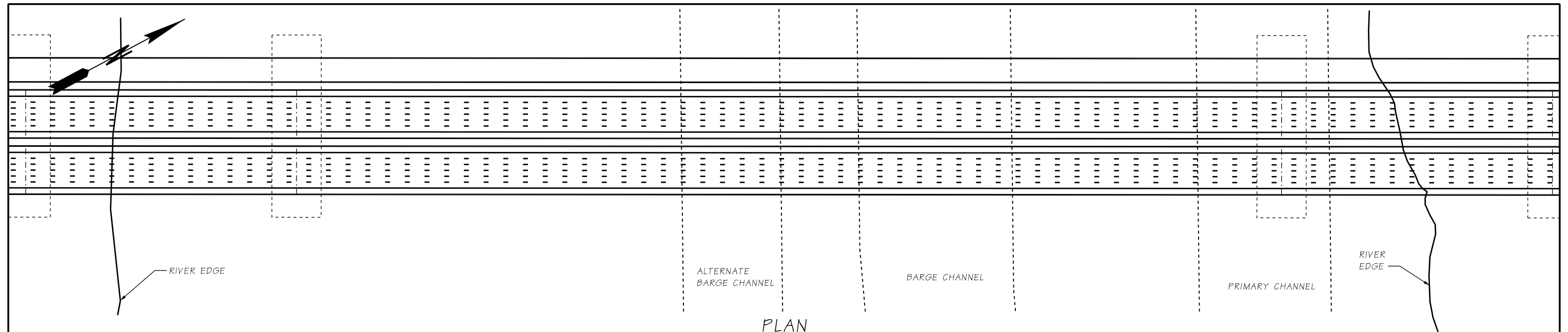

PLAN

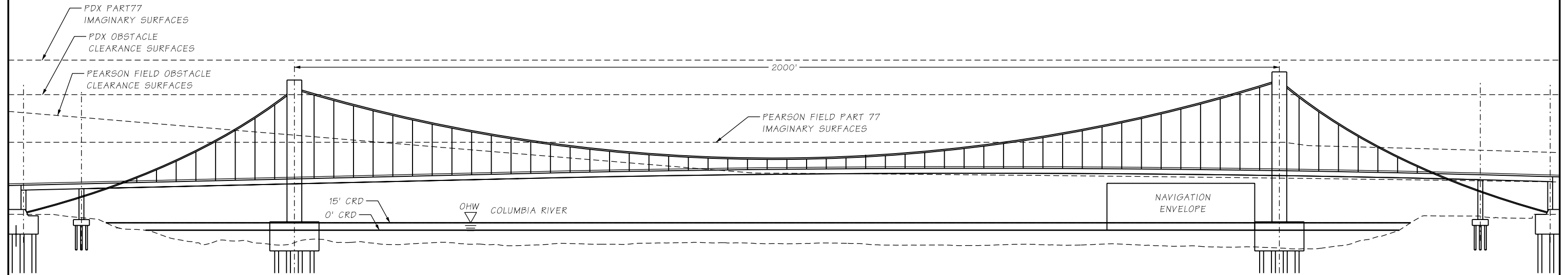

DEVELOPED ELEVATION

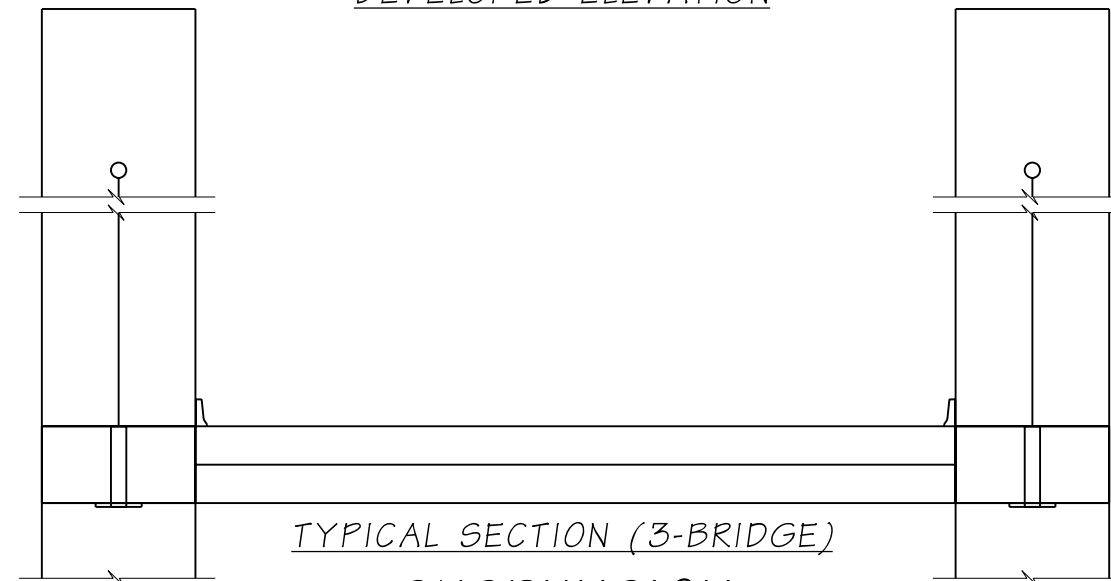

TYPICAL SECTION (3-BRIDGE)  
SUSPENSION

DESCRIPTION

**3-BRIDGE:**  
Three side-by-side suspension bridges. Each bridge has two towers with a 2000-foot main span between the 200-foot tall towers. One bridge carries 1-5 northbound (99 feet wide), one carries 1-5 southbound (99 feet wide), and one carries bike/ped and transit (50 feet wide).

**STACKED:**  
Two side-by-side suspension bridges. Each bridge has two towers with a 2000-foot main span between the 400-foot tall towers. One bridge carries 1-5 northbound and the other carries 1-5 southbound, bike/ped and/or transit is below 1-5. Both bridges are 99 feet wide.

- SKETCH -  
FOR  
DISCUSSION ONLY





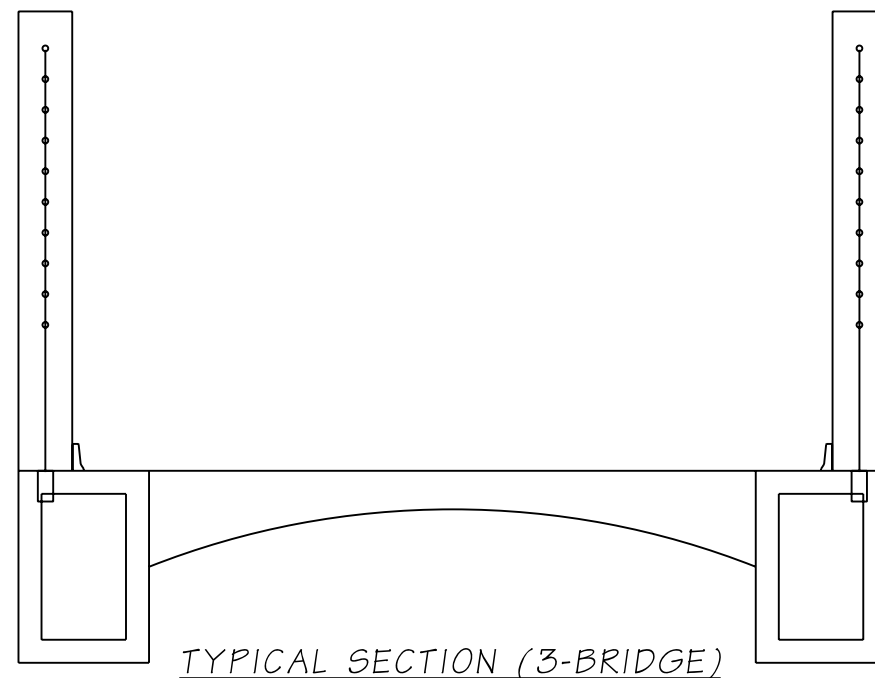
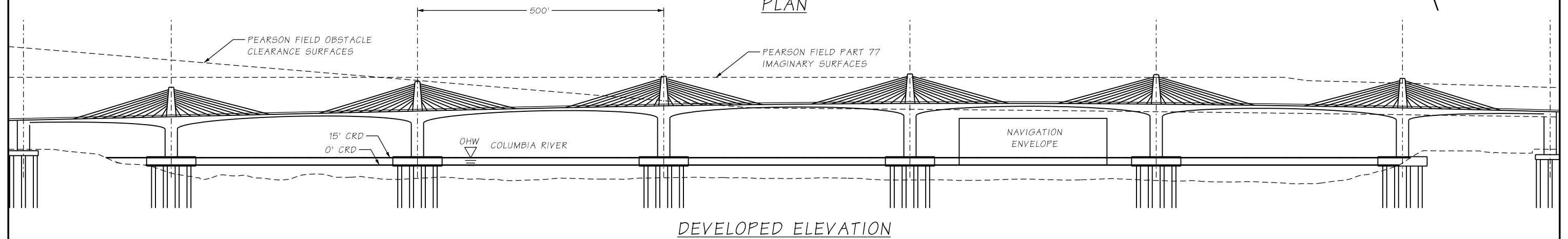
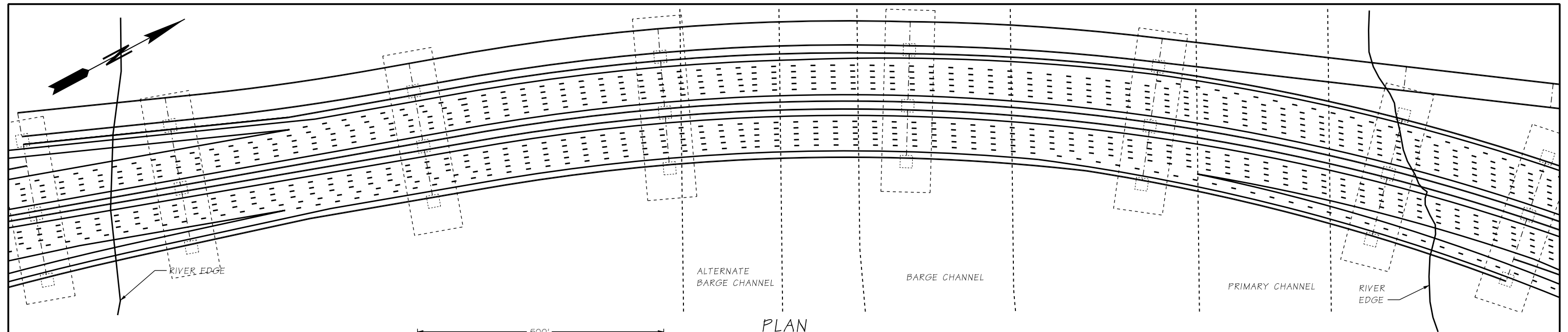

**DESCRIPTION**

**3-BRIDGE:**  
 Three side-by-side extradosed bridges. Each bridge has 500-foot spans between the 60-foot tall towers. One bridge carries 1-5 northbound (99 feet wide), one carries 1-5 southbound (99 feet wide), and one carries bike/ped and transit (50 feet wide).

**STACKED:**  
 Two side-by-side extradosed bridges. Each bridge has 500-foot main spans between the 60-foot tall towers. One bridge carries 1-5 northbound and the other carries 1-5 southbound, bike/ped and/or transit is below 1-5. Both bridges are 99 feet wide.

- SKETCH -  
 FOR  
 DISCUSSION ONLY

**Columbia River**  
**CROSSING**

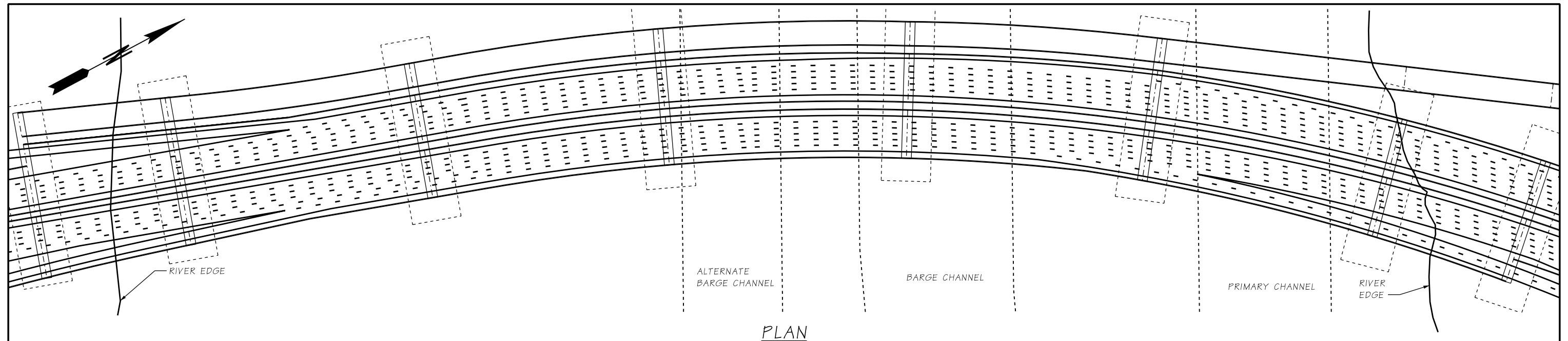

PLAN

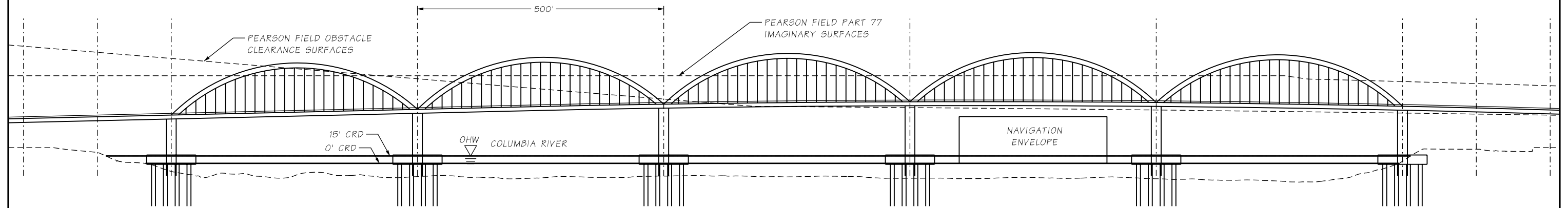

DEVELOPED ELEVATION

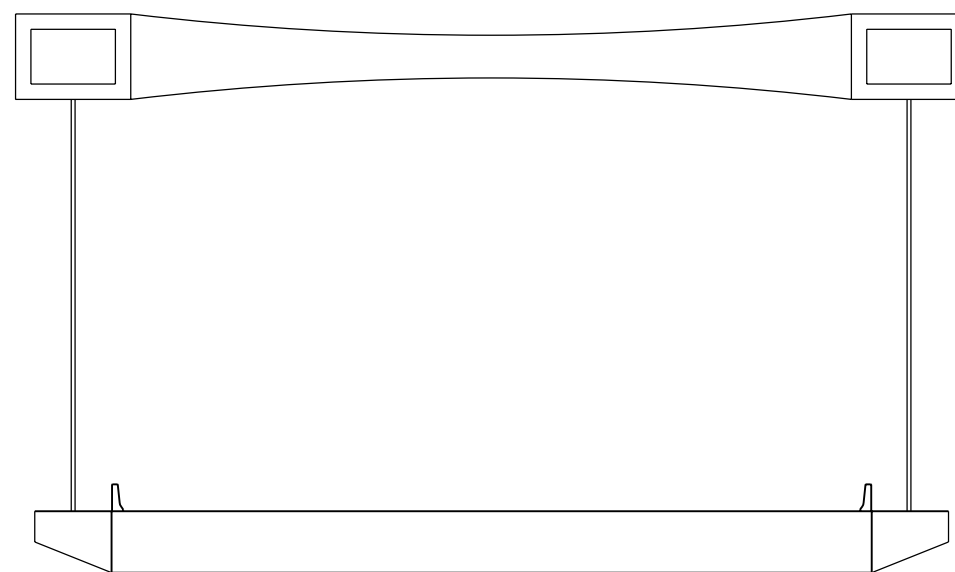

TYPICAL SECTION (3-BRIDGE)  
THROUGH ARCH

DESCRIPTION

**3-BRIDGE:**  
Three side-by-side through arch bridges. Each bridge has 500-foot spans. One bridge carries 1-5 northbound (99 feet wide), one carries 1-5 southbound (99 feet wide), and one carries bike/ped and transit (50 feet wide).

**STACKED:**  
Two side-by-side through arch bridges. Each bridge has 500-foot main spans. One bridge carries 1-5 northbound and the other carries 1-5 southbound, bike/ped and/or transit is below 1-5. Both bridges are 99 feet wide.

- SKETCH -  
FOR  
DISCUSSION ONLY

Columbia River  
**CROSSING**

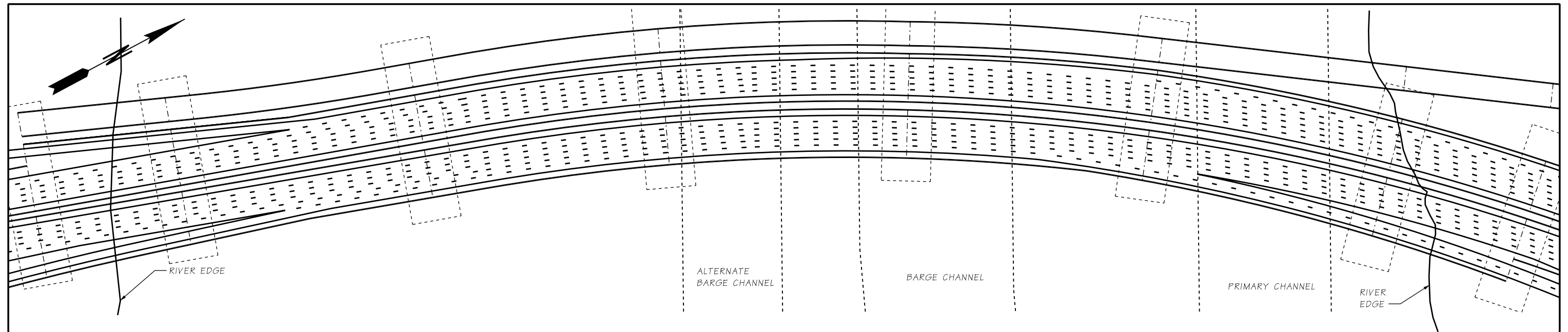

PLAN

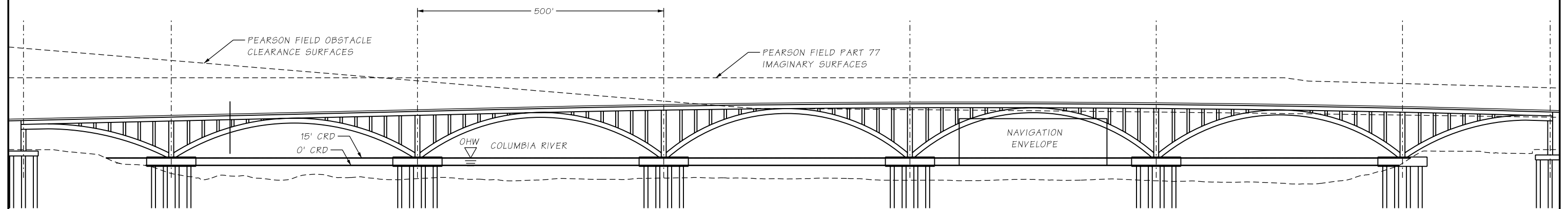

DEVELOPED ELEVATION

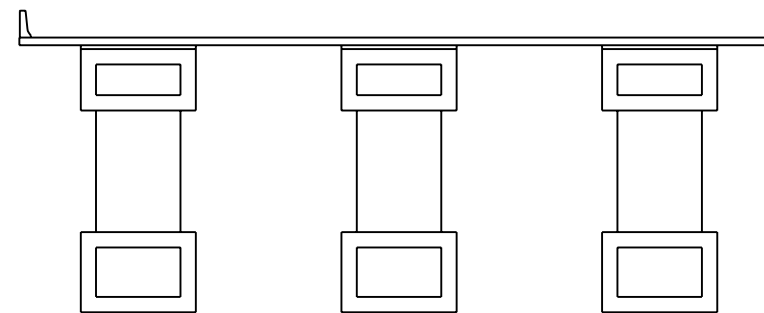

TYPICAL SECTION (3-BRIDGE)

DECK ARCH

DESCRIPTION

**3-BRIDGE:**  
 Three side-by-side deck arch bridges. Each bridge has 500-foot spans. One bridge carries I-5 northbound (99 feet wide), one carries I-5 southbound (99 feet wide), and one carries bike/ped and transit (50 feet wide).

**STACKED:**  
 Two side-by-side deck arch bridges. Each bridge has 500-foot main spans. One bridge carries I-5 northbound and the other carries I-5 southbound, bike/ped and/or transit is below I-5. Both bridges are 99 feet wide.

- SKETCH -  
 FOR  
 DISCUSSION ONLY



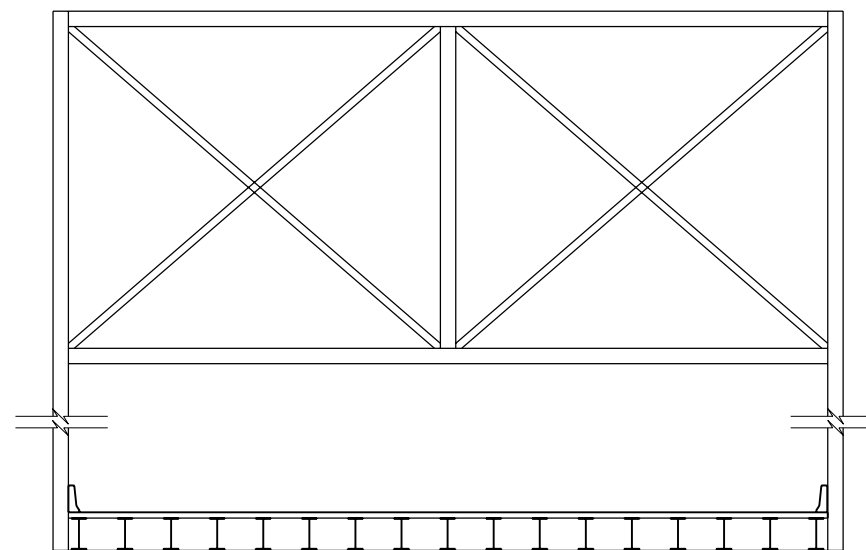
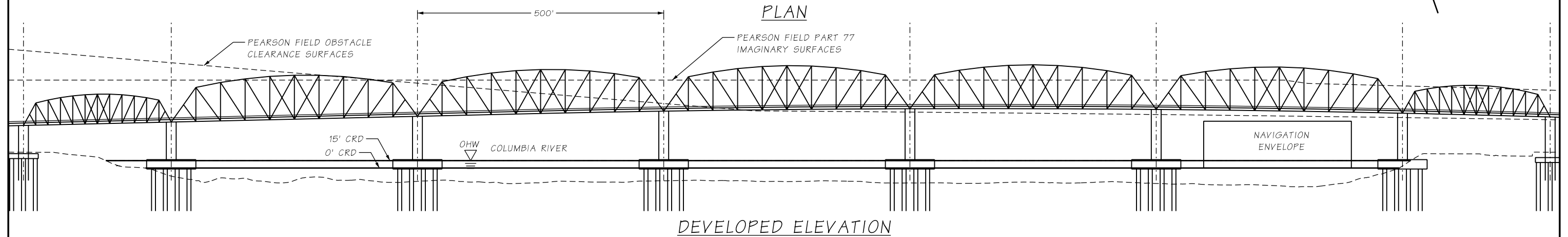
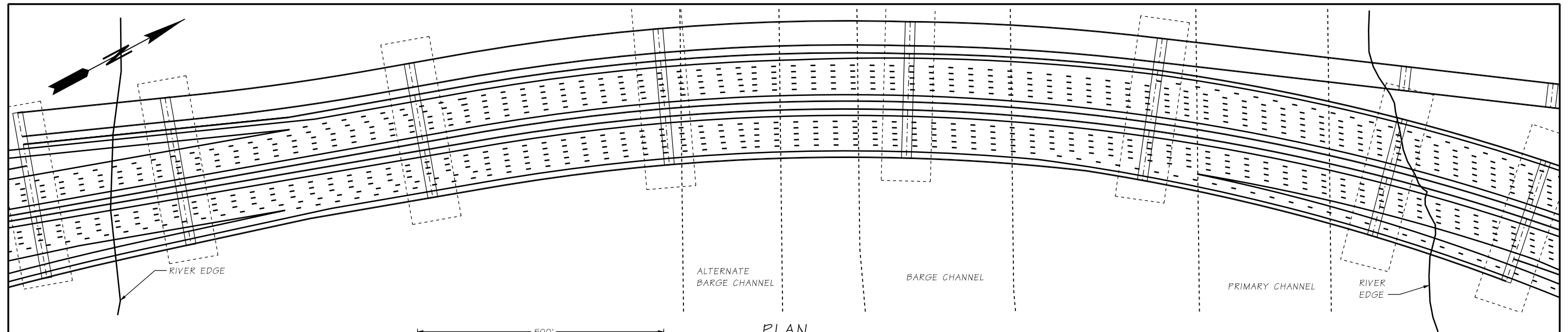

TYPICAL SECTION (3-BRIDGE)

THROUGH TRUSS

DESCRIPTION

**3-BRIDGE:**  
 Three side-by-side through truss bridges. Each bridge has 500-foot spans. One bridge carries I-5 northbound (99 feet wide), one carries I-5 southbound (99 feet wide), and one carries bike/ped and transit (50 feet wide).

**STACKED:**  
 Two side-by-side deck truss bridges. Each bridge has 500-foot main spans. One bridge carries I-5 northbound and the other carries I-5 southbound, bike/ped and/or transit is below I-5. Both bridges are 99 feet wide.

- SKETCH -  
 FOR  
 DISCUSSION ONLY



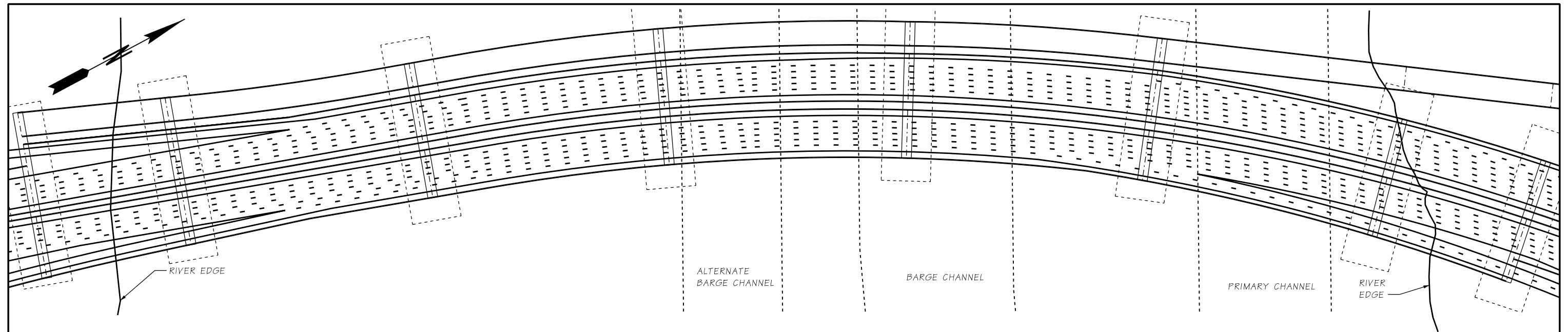

PLAN

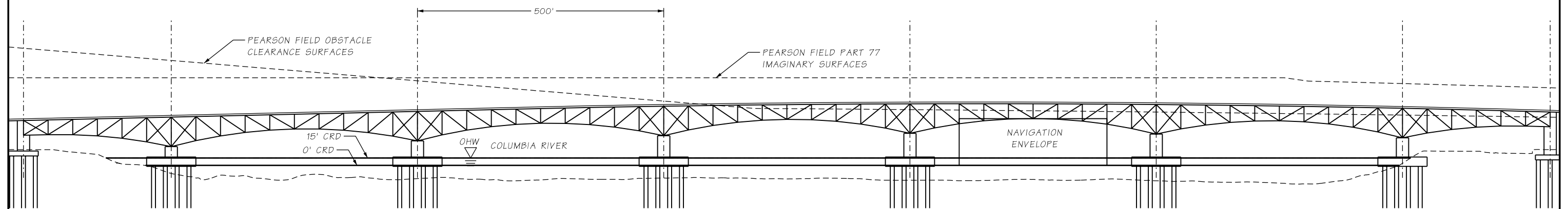

DEVELOPED ELEVATION

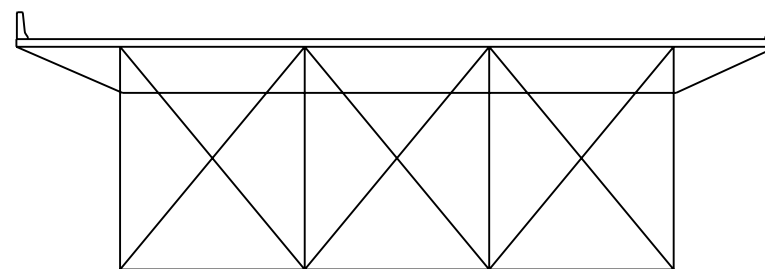

TYPICAL SECTION (3-BRIDGE)

DECK TRUSS

DESCRIPTION

**3-BRIDGE:**  
 Three side-by-side deck truss bridges. Each bridge has 500-foot spans. One bridge carries 1-5 northbound (99 feet wide), one carries 1-5 southbound (99 feet wide), and one carries bike/ped and transit (50 feet wide).

**STACKED:**  
 Two side-by-side deck truss bridges. Each bridge has 500-foot main spans. One bridge carries 1-5 northbound and the other carries 1-5 southbound, bike/ped and/or transit is below 1-5. Both bridges are 99 feet wide.

- SKETCH -  
 FOR  
 DISCUSSION ONLY



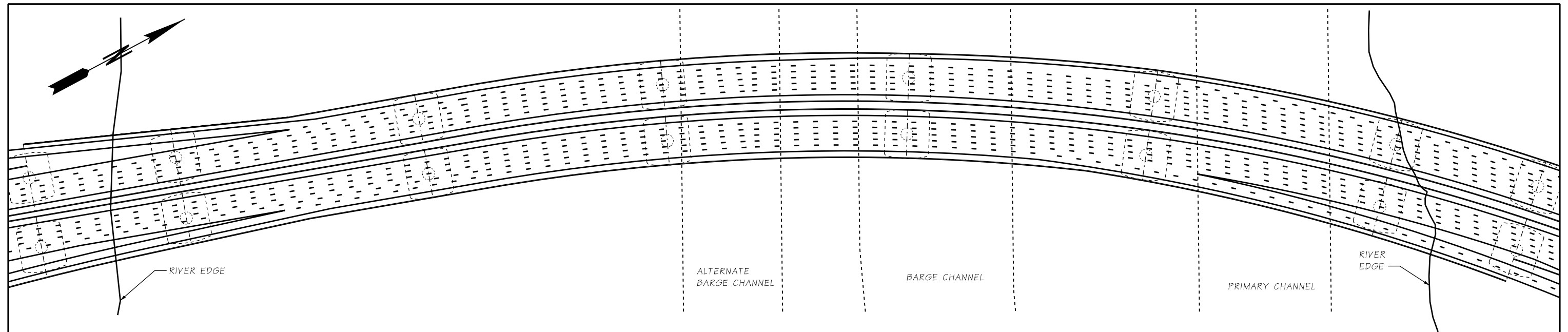

PLAN

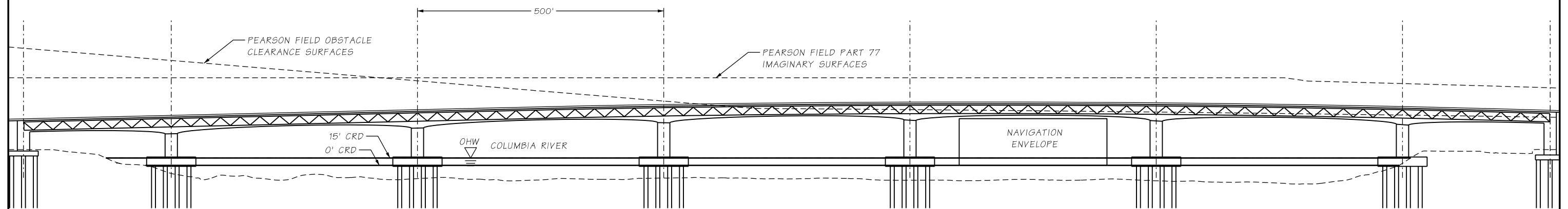

DEVELOPED ELEVATION

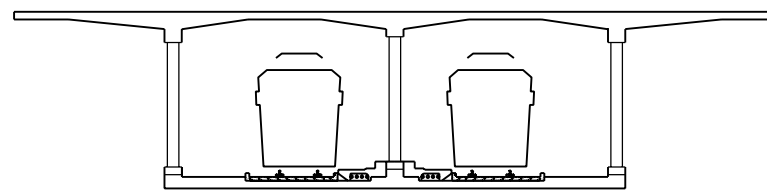

TYPICAL SECTION (STACKED)

OPEN WEB BOX GIRDER

DESCRIPTION

STACKED:  
 Two side-by-side open web box girder bridges. Each bridge has 500-foot main spans. One bridge carries 1-5 northbound and the other carries 1-5 southbound, bike/ped and/or transit is inside the box girder 1-5. Both bridges are 99 feet wide.

- SKETCH -  
 FOR  
 DISCUSSION ONLY

Columbia River  
**CROSSING**

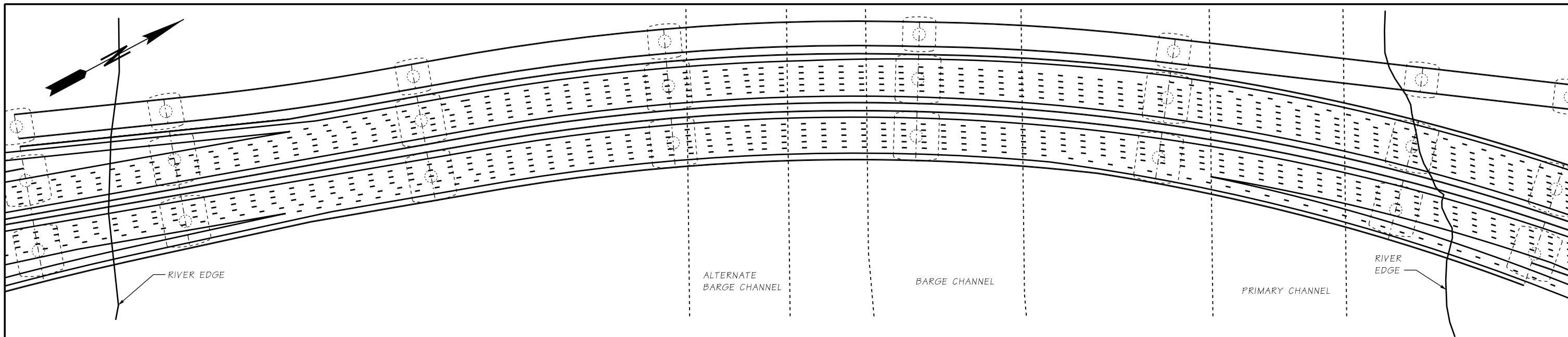

PLAN

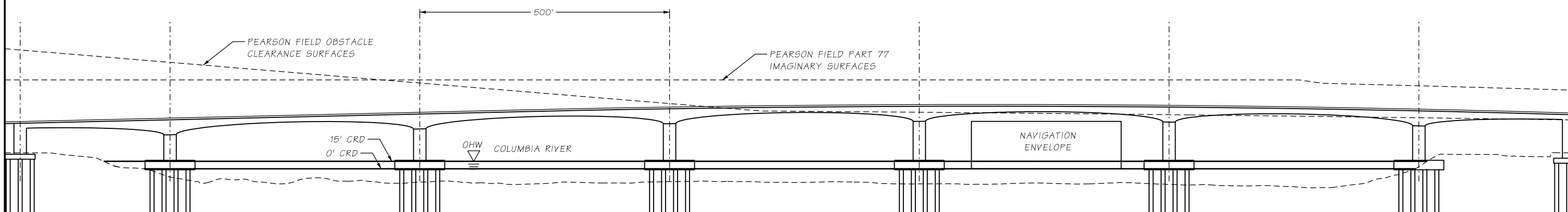

DEVELOPED ELEVATION

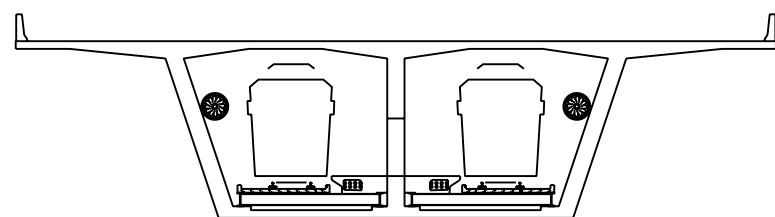

TYPICAL SECTION (STACKED)

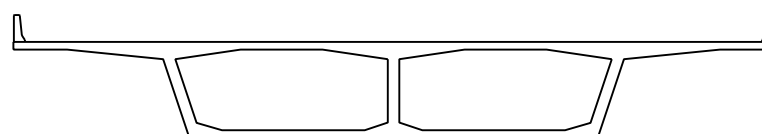

TYPICAL SECTION (3-BRIDGE)

CONCRETE SEGMENTAL

DESCRIPTION

**3-BRIDGE:**  
 Three side-by-side concrete segmental girder bridges. Each bridge has 500-foot spans. One bridge carries 1-5 northbound (99 feet wide), one carries 1-5 southbound (99 feet wide), and one carries bike/ped and transit (50 feet wide).

**STACKED:**  
 Two side-by-side concrete segmental girder bridges. Each bridge has 500-foot main spans. One bridge carries 1-5 northbound and the other carries 1-5 southbound, bike/ped and/or transit inside the girder. Both bridges are 99 feet wide.

- SKETCH -  
 FOR  
 DISCUSSION ONLY



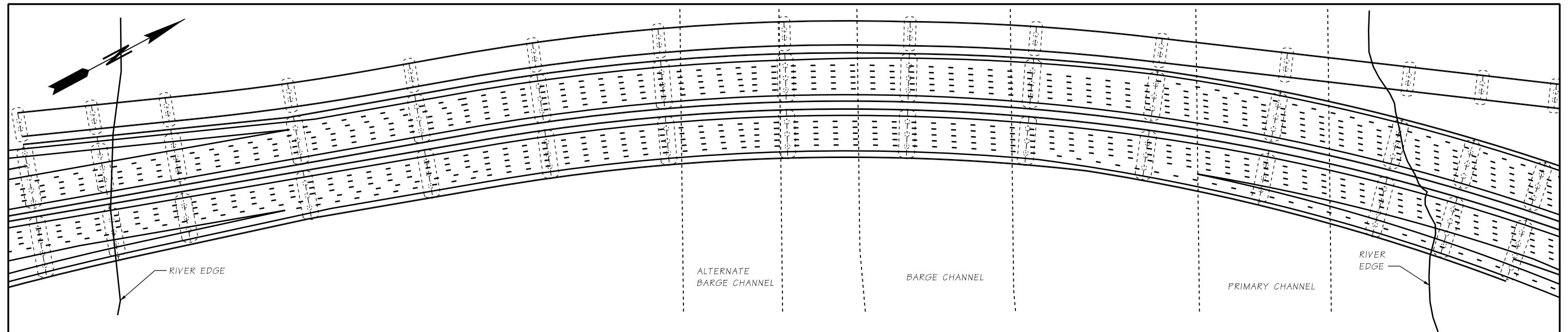

PLAN

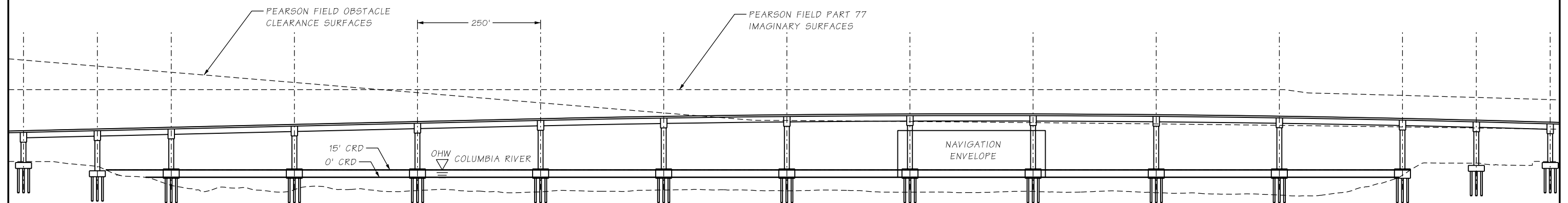

DEVELOPED ELEVATION

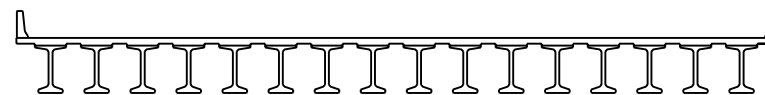

TYPICAL SECTION (3-BRIDGE)

CONCRETE GIRDER

DESCRIPTION

**3-BRIDGE:**  
 Three side-by-side concrete I-girder bridges. Each bridge has 250-foot spans. One bridge carries 1-5 northbound (99 feet wide), one carries 1-5 southbound (99 feet wide), and one carries bike/ped and transit (50 feet wide).

- SKETCH -  
 FOR  
 DISCUSSION ONLY





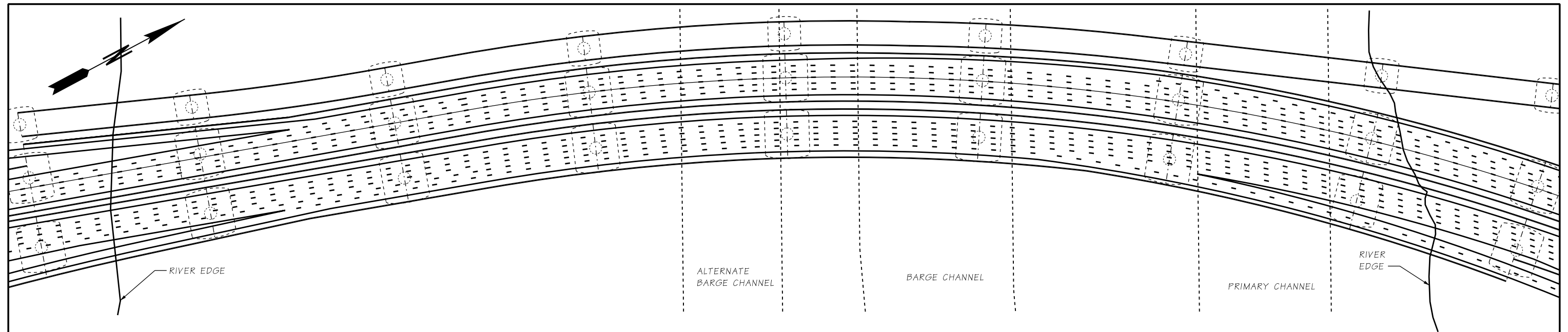

PLAN

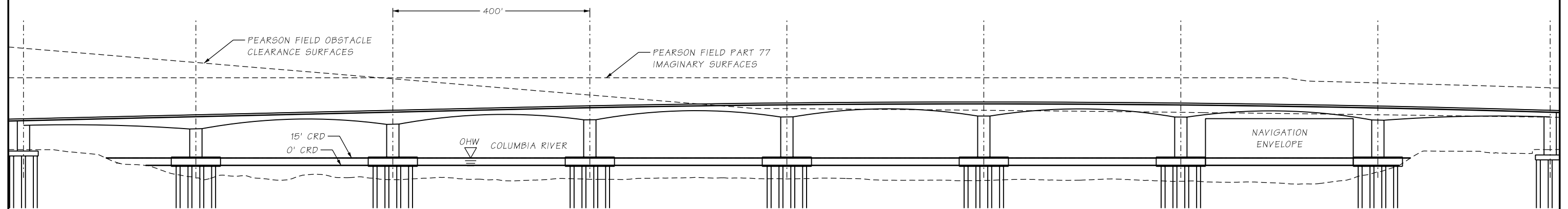

DEVELOPED ELEVATION

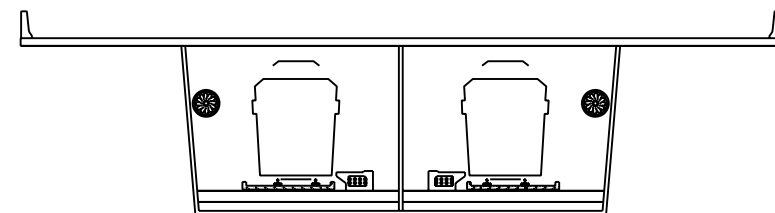

TYPICAL SECTION (STACKED)

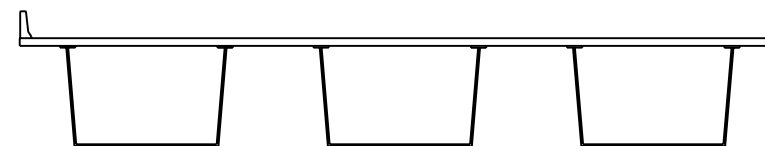

TYPICAL SECTION (3-BRIDGE)

DESCRIPTION

**3-BRIDGE:**  
 Three side-by-side steel box girder bridges. Each bridge has 400-foot spans. One bridge carries I-5 northbound (99 feet wide), one carries I-5 southbound (99 feet wide), and one carries bike/ped and transit (50 feet wide).

**STACKED:**  
 Two side-by-side steel box girder bridges. Each bridge has 400-foot main spans. One bridge carries I-5 northbound and the other carries I-5 southbound, bike/ped and/or transit is below I-5. Both bridges are 99 feet wide.

- SKETCH -  
 FOR  
 DISCUSSION ONLY

STEEL BOX GIRDER

Columbia River  
**CROSSING**

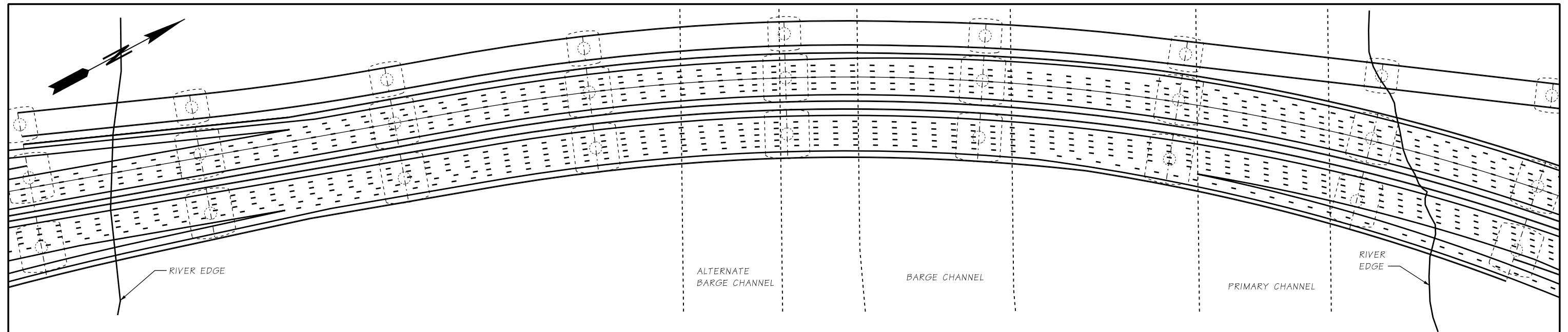

PLAN

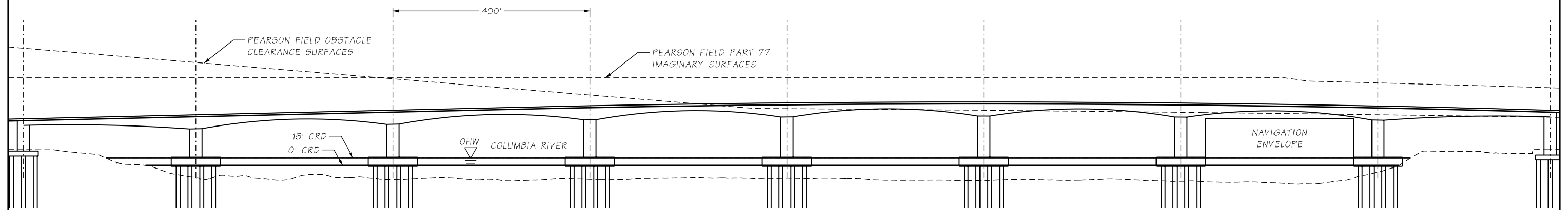

DEVELOPED ELEVATION

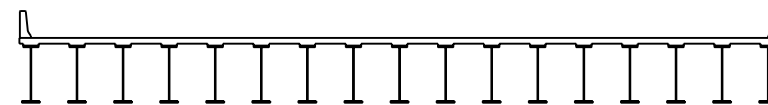

TYPICAL SECTION (3-BRIDGE)

STEEL I-GIRDER

DESCRIPTION

**3-BRIDGE:**  
 Three side-by-side steel I-girder bridges. Each bridge has 400-foot spans. One bridge carries I-5 northbound (99 feet wide), one carries I-5 southbound (99 feet wide), and one carries bike/ped and transit (50 feet wide).

- SKETCH -  
 FOR  
 DISCUSSION ONLY



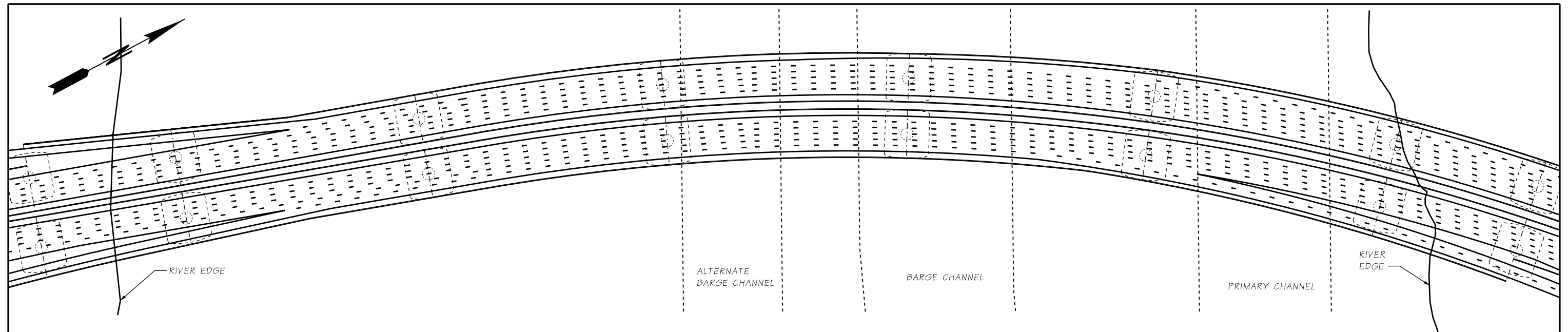

PLAN

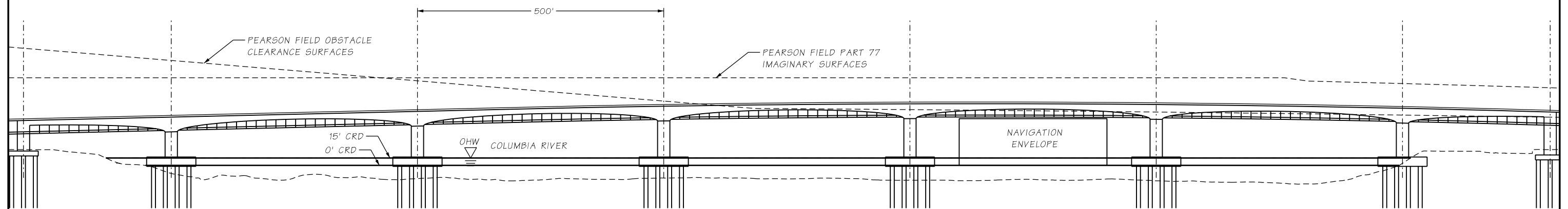

DEVELOPED ELEVATION

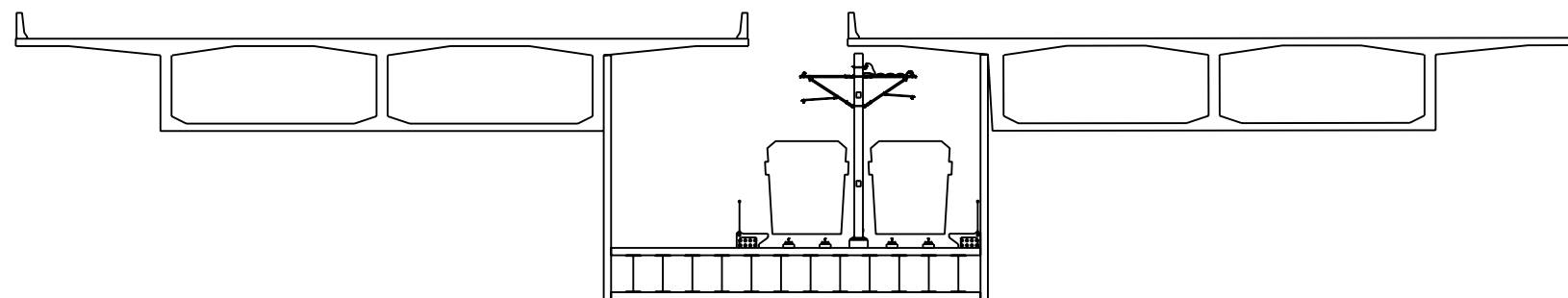

TYPICAL SECTION  
SUSPENDED FRAME

DESCRIPTION

Two side-by-side concrete segmental girder bridges with a third steel frame structure suspended between the two bridges. Each bridge has 500-foot main spans. One concrete segmental bridge carries 1-5 northbound (99 feet wide) and the other carries 1-5 southbound (99-feet wide). The 50-foot wide bike/ped and transit is carried on the suspended steel frame.

- SKETCH -  
FOR  
DISCUSSION ONLY

Columbia River  
**CROSSING**

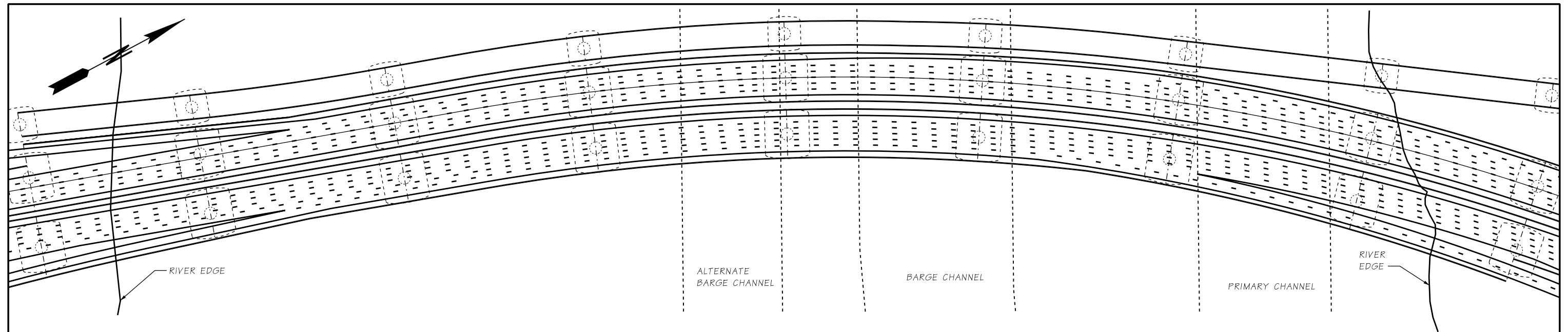

PLAN

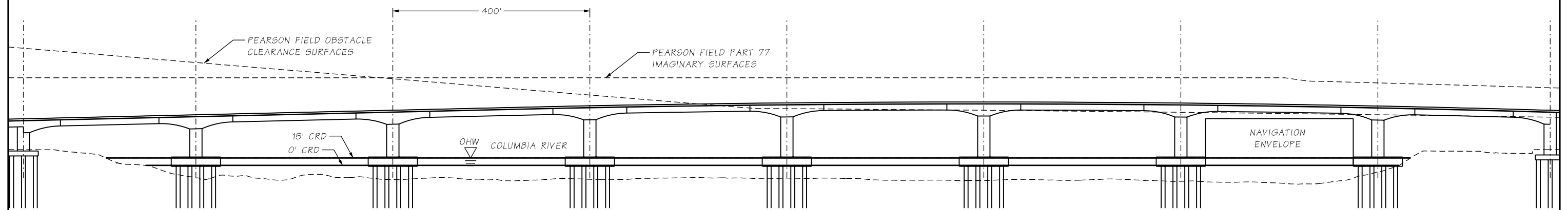

DEVELOPED ELEVATION

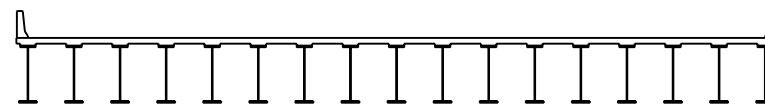

TYPICAL SECTION (3-BRIDGE)  
 HAUNCHED CONCRETE BOX GIRDER  
 WITH CONCRETE I-GIRDER DROP-IN

DESCRIPTION

3-BRIDGE:  
 Three side-by-side bridges. Each bridge has 400-foot spans. One bridge carries 1-5 northbound (99 feet wide), one carries 1-5 southbound (99 feet wide), and one carries bike/ped and transit (50 feet wide).

- SKETCH -  
 FOR  
 DISCUSSION ONLY



## **APPENDIX B**

### **Performance and Cost Attribute Voting Scales**

**This page left blank intentionally.**

## Performance and Cost Attribute Voting Scales

### In-Water Work Impacts

Rating	Definition	Score
None	No significant impacts to either the environment or marine traffic due to in-water work.	100% (1.0)
Minor	In-water work impacts are significantly lower than what would normally be perceived as acceptable and reasonable.	80% (0.8)
Moderate	In-water work impacts are acceptable and reasonable.	60% (0.6)
Major	In-water work impacts are significantly higher than what would normally be perceived as acceptable and reasonable.	40% (0.4)
Severe	In-water work impacts are severe and will cause significant disruptions.	20% (0.2)

### Structural Complexity

Rating	Definition	Score
Very Simple	Simple span bulb tee girder	95% (0.95)
Simple	Steel plate girder	80% (0.8)
Somewhat Complex	Steel box girder	60% (0.6)
Moderately Complex	Segmental	40% (0.4)
Very Complex	Cable-stay, extradosed, suspension, composite girder	20% (0.2)
Extremely Complex	Self-anchored suspension bridge	5% (0.05)

**Aesthetic Opportunity**

Rating	Definition	Score
Excellent	Opportunities for aesthetic treatment and creative expression are virtually unlimited. A structure that allows almost unlimited variability in manipulation of all vertical and horizontal elements.	100% (1.0)
Good	Opportunities for aesthetic treatment and creative expression are above average for a major river crossing. A structure that allows a high level of variability in manipulation of all vertical and horizontal elements.	80% (0.8)
Fair	Opportunities for aesthetic treatment and creative expression are fair for a major river crossing. A structure that allows some level of variability in manipulation of all vertical and horizontal elements.	60% (0.6)
Poor	Opportunities for aesthetic treatment and creative expression are below average for a major river crossing. A structure that allows some level of variability in manipulation of either vertical or horizontal elements.	40% (0.4)
Very Poor	Opportunities for aesthetic treatment and creative expression are extremely limited.	20% (0.2)

**Maintainability**

Rating	Definition	Score
Excellent	The bridge is expected to be very easy and inexpensive to operate and maintain.	100% (1.0)
Good	The bridge is expected to be easier and less expensive to operate and maintain than normal.	80% (0.8)
Fair	The bridge meets normal expectations for operations and maintenance.	60% (0.6)
Poor	The bridge is expected to be more difficult and expensive to operate and maintain than normal.	40% (0.4)
Very Poor	The bridge is expected to be difficult and expensive to operate and maintain.	20% (0.2)



**Project Schedule**

Rating	Definition	Score
Excellent	The project schedule is expected to be significantly shorter than average for a project of this kind.	95% (0.95)
Good	The project schedule is expected to be shorter than average for a project of this kind.	75% (0.75)
Average	The project schedule is expected to be about what one would expect for a typical concrete segmental box girder bridge (i.e., Glen Jackson Bridge)	50% (0.50)
Poor	The project schedule is expected to be longer than average for a project of this kind.	25% (0.25)
Very Poor	The project schedule is expected to be longer than average for a project of this kind.	5% (0.05)

**Operational Reliability**

Rating	Definition	Score
Excellent	Bridge type has virtually fewer than average concerns with respect to safety and security.	75% (0.75)
Average	Bridge has typical concerns related to safety and security.	50% (0.50)
Very Poor	Bridge type creates significant concerns relevant to the safety and security of emergency response and reliability of transit and interstate operations	25% (0.25)

**Cost**

Rating	Definition	Weight
Highest	Highest cost alternative.	0.65
Higher		0.58
Medium		0.50
Lower		0.42
Lowest	Lowest cost alternative.	0.35

This page left blank intentionally.